

IMPORTANT:
THESE INSTRUCTIONS ARE TO
REMAIN WITH THE HOMEOWNER.
PLEASE SAVE THESE INSTRUCTIONS.

**PACIFIC
ENERGY**

SERIAL #

SAFETY NOTICE

If this stove is not properly installed, a house fire may result. For your safety, follow the installation instructions. Contact local building or fire officials about restrictions and installation inspection requirements in your area.

INSTALLATION AND OPERATING INSTRUCTIONS

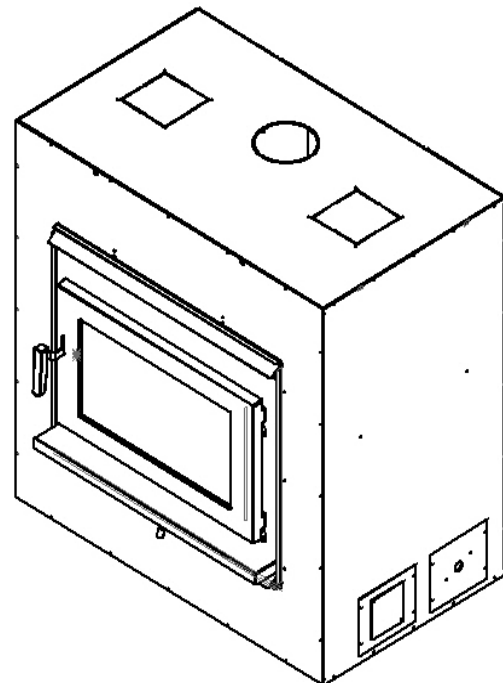

TESTED and LISTED to CAN/ULC
S610-M87 AND UL 127
Meets the Environmental Protection
Agency's July 1990 Particulate Emission
Standards



MODEL: PACIFIC FP30

**ZERO CLEARANCE WOOD
FIREPLACE**

Contents

NOTE:

WE STRONGLY RECOMMEND THAT SMOKE DETECTORS BE INSTALLED.

If smoke detectors have been previously installed, you may notice that they are operating more frequently. This may be due to curing of stove paint or fumes caused by accidentally leaving the fire door open. Do not disconnect the detectors. If necessary, relocate them to reduce their sensitivity.

SAFETY NOTICE:

If this stove is not properly installed, a house fire may result. For your safety, follow the installation instructions. Contact local building or fire officials about restrictions and installation inspection requirements in your area.

Please read this entire manual before you install and use your new room heater. Failure to follow instructions may result in property damage, bodily injury, or even death.

Safety and Maintenance.....	3
Creosote	4
Formation and Need for Removal.....	4
Chimney Fires.....	4
In the event of a Chimney Fire.....	4
Avoiding a Chimney Fire.....	4
Operation.....	5
Wood Selection.....	5
How to Test Your Wood	5
Lighting for the First Time	5
Lighting a Fire.....	5
Normal Operation	5
Restarting After Extended or Overnight Burns.....	5
More Wood, More Heat.....	6
Proper Draft	6
Ash Removal	6
Disposal of Ashes	6
Blower Operation	6
Baffle Removal	6
Removal.....	6
Secondary Air Box Cleaning.....	6
Glass Cleaning	6
Blower Replacement	7
Firebrick Installation.....	8
Crate Removal.....	9
Locating The FP30 Fireplace.....	9
Fireplace Installation	9
Dimensions	10
Clearances	10
Procedure:.....	10
Minimum Framing Dimensions.....	11
Framing Kit Assembly	12
Minimum Clearances to Combustibles.....	13
Listed Chimney and Chimney Connector	15
Chase Enclosure	15
Offsets	16
Combustion Air.....	17
Outside Air Adapter.....	17
Safety Strip	18
Blower Wiring.....	18
Floor Protector	18
Remote Heat Duct Installation.....	19
Facing and Air Inlet	21
Cement Board Installation	21
Mantel Clearances	22
Appendix A.....	23
Troubleshooting	23
Understanding & Operating Your Pacific Energy Stove.....	24
Replacement Parts	25
Label Location	27
Label.....	27

Safety and Maintenance

1. **Burn only, dry and well seasoned cord wood.** The denser or heavier the wood when dry, the greater its heat value. This is why hardwoods are generally preferred. Green or wet wood should not be used, it will reduce heat output, as well as, contributing significantly to creosote buildup.

WARNING: NEVER USE CHEMICALS OR ANY OTHER VOLATILE LIQUID TO START A FIRE. DO NOT BURN GARBAGE OR FLAMMABLE FLUIDS SUCH AS GASOLINE, NAPHTHA, OR ENGINE OIL. WE STRONGLY RECOMMEND THAT SMOKE DETECTORS BE INSTALLED.

2. Remove ashes frequently. Embers can roll out the door and create a fire hazard. Maintain a 1" minimum ash base.
3. The area where boost combustion air enters the firebox must be kept clear of excessive ash buildup which will block air flow. This area is at the front of the firebox.
4. If glass becomes darkened through slow burning or poor wood, it can be cleaned with fireplace glass cleaner when the stove is cold. Never scrape with an object that might scratch the glass. The type and amount of deposit on the glass is a good indication of the flue pipe and chimney buildup. A light brown dusty deposit that is easily wiped off usually indicates good combustion and dry, well-seasoned wood and therefore relatively clean pipes and chimney. On the other hand, a black greasy deposit that is difficult to remove is a result of wet and green wood and too slow a burning rate. This heavy deposit is building up as quickly in the chimney.
5. Establish a routine for the fuel, wood burning and firing technique. Check daily for creosote buildup until experience shows how often you need to clean to be safe.

WARNING: ONLY USE MATERIALS AND COMPONENTS SUPPLIED OR SPECIFIED BY MANUFACTURER WHEN DOING MAINTENANCE OR REPLACEMENTS. DO NOT USE A FIREPLACE INSERT TO OTHER PRODUCTS NOT SPECIFIED FOR USE WITH THIS FIREPLACE.

6. **DOOR GASKETS** - The gasket used by Pacific Energy (7/8" medium density fibreglass rope) requires only light pressure to seal. This will prolong seal life. It is important that the door seal be maintained in good condition. Periodically inspect seals and replace if necessary. 7. **DOOR GLASS** - Replacement glass can be obtained from your dealer. Use 11 3/8" x 21 5/8" x 5 mm.

WARNING: DO NOT SUBSTITUTE GLASS WITH ANY OTHER TYPE MATERIAL OTHER THAN CERAMIC GLASS

WARNING: DO NOT SLAM LOADING DOOR OR OTHERWISE IMPACT GLASS. WHEN CLOSING DOOR, MAKE SURE THAT NO LOGS PROTRUDE TO IMPACT THE GLASS. IF THE GLASS GETS CRACKED OR BROKEN, IT MUST BE REPLACED BEFORE USING THE STOVE.

WARNING: OVER FIRING THE APPLIANCE WILL SHORTEN THE LIFE OF THE PRODUCT. FAILURE TO RECTIFY AN OVER FIRING CONDITION CAN BE HAZARDOUS AND MAY VOID THE MANUFACTURER'S WARRANTY.

To remove broken glass, remove the door gasket and clean out the screw heads. Remove the screws that hold the retainers and remove the retainers, noting position for re-assembly. Remove all particles of glass. Be careful as they are very sharp. Install new glass complete with gasket. Replace retainers, screws and gasket.

CAUTION:

- **DO NOT OVERTIGHTEN, TIGHTEN SCREWS HAND TIGHT**
 - **DO NOT CLEAN GLASS WHEN HOT**
 - **DO NOT USE ABRASIVE CLEANERS ON GLASS**
8. Do not store wood within heater installation clearances, or within the space required for fuel loading and ash removal. Keep the area around the heater clean and free of loose combustibles, furniture, newspapers, etc.
 9. Be aware that the hotter the fire, the less creosote is deposited. Weekly cleaning may be necessary in mild weather, even though monthly cleaning is usually enough in the coldest months when burning rates are higher.
 10. Instruct all members of your family on the safe operation of the heater. Ensure they have enough knowledge of the entire system if they are expected to operate it. Stress the section on chimney fires and the importance of following the steps outlined "In Case of Chimney Fire".
 11. Inspect and clean your chimney system at the beginning of the burning season before your first fire and at least every two months during the burning season. Inspect the interior and exterior of the pipe for defects and/or damage. Remove and inspect the rain cap. Refer to the chimney system manufacturer's installation instructions for the procedure to remove and or replace any necessary components to the chimney system.
 12. Maintain a distance of 30" to all combustible materials in the room.
(see Floor Protection for Floor Protection dimensions)

Creosote

Formation and Need for Removal

When wood is burned slowly, it produces tar and other organic vapours, which combine with expelled moisture to form creosote. The creosote vapours condense in the relatively cool chimney flue of a slow burning fire. As a result, creosote residue accumulates on the flue lining. When ignited, this creosote makes an extremely hot fire. The chimney connector and chimney should be inspected periodically (at least once every two months) during the heating season to determine if a creosote buildup has occurred. If creosote has accumulated (3 mm. or more), it should be removed to reduce the risk of a chimney fire.

1. Highest smoke densities occur when a large amount of wood is added to a bed of hot coals and the air inlet is closed. The heated wood generates smoke, but without ample air, the smoke cannot burn. Smoke-free, clean burning requires small fuel loads, two or three logs at a time or 1/4 to 1/2 of fuel load and leaving the air inlet relatively wide open, especially during the first 10 to 30 minutes after each loading, when most of the smoke generating reactions are occurring. After 30 minutes or so, the air inlet can be turned down substantially without excessive smoke generation. Wood coals create very little creosote-producing smoke.
2. The cooler the surface over which the wood smoke is passing, the more creosote will be condensed. Wet or green wood contributes significantly to creosote formation as the excess moisture that is boiled off cools the fire, making it difficult for the tars and gases to ignite, thus creating dense smoke and poor combustion. This moisture-laden smoke cools the chimney, compounding the problem by offering the smoke the ideal place to condense. In summary, a certain amount of creosote is inevitable and must be lived with. Regular inspection and cleaning is the solution. The use of dry, seasoned wood and ample combustion air will help to minimize the buildup.

Chimney Fires

The result of excessive creosote buildup is a chimney fire. Chimney fires are dangerous. Temperatures inside the chimney can exceed 2000° F. This causes much higher than normal temperatures on its exterior surfaces. Thus ignition of nearby or touching combustible material is more likely during a chimney fire. Proper clearances are critical during such a fire. Chimney fires are easy to detect; they usually involve one or more of the following:

- Flames and sparks shooting out of the top of the chimney
- A roaring sound
- Vibration of the chimney

In the event of a Chimney Fire

1. Prepare to evacuate to ensure everyone's safety. Have a well understood plan of action for evacuation. Have a place outside where everyone is to meet.
2. Close air inlet on stove.

3. Call local fire department. Have a fire extinguisher handy. Contact your local municipal or provincial fire authority for further information on how to handle a chimney fire. It is most important that you have a clearly understood plan on how to handle a chimney fire.
4. After the chimney fire is out, the chimney must be cleaned and checked for stress and cracks before starting another fire. Also check combustibles around the chimney and the roof.

- The services of a competent or certified installer, (certified by the Wood Energy Technical Training program (WETT) - in Canada, Hearth Education Foundation (HEARTH) - in U.S.A.,) are strongly recommended.

Avoiding a Chimney Fire

There are two ways to avoid chimney fires:

1. Do not let creosote build up to a point where a chimney fire is possible.
2. Do not have fires in the heater that may ignite chimney fires. These are very hot fires, such as when burning household trash, cardboard, Christmas tree limbs, or even ordinary fuel wood; (e.g.. with a full load on a hot bed of coals and with the air inlet excessively open.)

Operation

CAUTION: HOT WHILE IN OPERATION. KEEP CHILDREN, CLOTHING AND FURNITURE AWAY. CONTACT MAY CAUSE SKIN BURNS.

WARNING: OVER FIRING THE APPLIANCE WILL SHORTEN THE LIFE OF THE PRODUCT. FAILURE TO RECTIFY AN OVER FIRING CONDITION CAN BE HAZARDOUS AND MAY VOID THE MANUFACTURER'S WARRANTY.

CAUTION: Never use gasoline, gasoline type lantern fuel, kerosene, charcoal lighter fluid or similar liquids to start or "freshen up" a fire in this heater. Keep all such liquids well away from the heater while it is in use.

DO NOT BURN :

- | | |
|--------------------|----------------|
| -Salt water wood * | -Treated wood |
| -Wet or green wood | -Coal charcoal |
| -Garbage/Plastic * | -Solvents |

* **These materials contain chlorides which will rapidly destroy metal surfaces and void warranty.**

Your PACIFIC ENERGY heater is designed for maximum overall efficiency at a moderate firing rate. Over firing is hazardous and a waste of fuel. Too slow a burn contributes to creosote buildup and lowers combustion efficiency.

Wood Selection

This heater is designed to burn natural wood only. Higher efficiency and lower emissions generally result when burning air-dried seasoned hardwoods, as compared to softwoods or to green or freshly cut hardwoods.

Wood should be properly air dried (seasoned) for six months or more. Wet or undried wood will cause the fire to smoulder and produce large amounts of creosote. Wet wood also produces very little heat and tends to go out often.

Do not burn anything but wood. Other fuels, eg. charcoal, can produce large amounts of carbon monoxide, a tasteless, odourless gas that can kill. Under no circumstances should you attempt to barbecue in this heater.

How to Test Your Wood

Add a large piece of wood to the stove when it has a good large bed of coals. It is dry if it is burning on more than one side within one minute. It is damp if it turns black and lights within three minutes. If it sizzles, hisses and blackens without igniting in five minutes it is soaked and should not be burnt.

Lighting for the First Time

Curing of the Paint Finish/Insulation

To achieve the best finish, the paint on your stove must be baked on. When burning your stove for the first 2-3 times it is very important that the room be well ventilated. Open all windows and doors. Smoke and fumes caused by the curing process may cause discomfort to some individuals.

Lighting a Fire

WARNING: Never use chemicals or any other volatile liquid to start a fire.

1. Adjust air control to far left position and open door.

2. Place crumpled newspaper in the centre of the heater and crisscross with several pieces of dry kindling. Add a few small pieces of dry wood on top.
3. Ignite the paper and close the door. (Depending on length of chimney installation, you may need to leave door open approximately 1/2" until kindling is fully ignited.) **DO NOT LEAVE STOVE UNATTENDED WHILE DOOR IS OPEN.**
4. After the fire has established itself, open the door and add a few small logs. Close door.
5. Begin normal operation after a good coal base exists and wood has charred.

Normal Operation

1. Set air control to a desired setting. If smoke pours down across the glass (waterfall effect) this indicates you have shut the control down too soon or you are using too low a setting. The wide range control makes finding the desired setting for your application easy. As every home's heating needs vary, (ie. insulation, windows, climate, etc.) the proper setting can only be found by trial and error and should be noted for future burns.
2. To refuel, adjust air control to far left position, and give the fire time to brighten. Open the door slowly, this will prevent back puffing.
3. Use wood of different shape, diameter and length (up to 20"). Load your wood endwise and try to place the logs so that the air can flow between them. Always use dry wood.
4. Do not load fuel to a height or in such a manner that would be hazardous when opening the door.
5. For extended or overnight burns, unsplit logs are preferred. Remember to char the wood completely on maximum setting before adjusting air control for overnight burn.

WARNING: Always keep loading door closed when burning. This heater is not designed for open door burning. If unit is operated with the door open, gas and flame may be drawn out of the fireplace opening creating risks of both fire and smoke.

WARNING: No alteration or modification of the combustion air control assembly is permitted. Any tampering will void warranty and could be very hazardous.

WARNING: Do not use grates or andirons to elevate the fuel. Burn directly on the fire bricks. Replace broken or missing bricks. Failure to do so may create a hazardous condition.

Restarting After Extended or Overnight Burns

1. Open door and rake hot embers towards the front of the heater. Add a couple of dry, split logs on top of embers, close door.
2. Adjust air control to the far left position and in just a few minutes, logs should begin burning.
3. After wood has charred, reset air control to desired setting.
4. To achieve maximum firing rate, set control to high. Do not use this setting other than for starting or preheating fresh fuel loads.

DO NOT OVER FIRE THIS HEATER: ATTEMPTS TO ACHIEVE HEAT OUTPUT RATES THAT EXCEED HEATER DESIGN SPECIFICATIONS CAN RESULT IN PERMANENT DAMAGE TO THE HEATER AND CHIMNEY AND MAY VOID MANUFACTURERS WARRANTY.

More Wood, More Heat

Seasoned wood has approximately 7500 BTU's per pound. If you put 10 pounds of wood in your stove for an eight hour burn the wood will be producing 9375 BTU's per hour average. (7500 BTU x 10 lbs./8hrs.=9375 BTU's per hr.) If you put 20 lbs of wood in your stove for eight hour burn you will get 18,750 BTU's per hr. (7500 BTU x 20lbs./8hr.=18,750 BTU's per hr.). This is only an example and is based on 100% efficiency. In reality, your stove should perform above the 80% range. Experience will give you the right settings for proper combustion and efficient burning. Remember the correct air inlet setting is affected by variables such as type of wood, outside temperature, chimney size and weather conditions. With practice, you will become proficient in operating your heater and will obtain the performance for which it was designed.

Proper Draft

1. Draft is the force which moves air from the appliance up through the chimney. The amount of draft in your chimney depends on the length of the chimney, local geography, nearby obstructions and other factors.
2. Too much draft may cause excessive temperatures in the appliance. An uncontrollable burn or a glowing red stove part or chimney indicates excessive draft.
3. Inadequate draft may cause back puffing into the room and plugging of the chimney. Smoke leaking into the room through appliance and chimney connector joints indicates inadequate draft.

Ash Removal

Caution: Ashes are to be removed only when the heater is cold. Whenever ashes get 3 to 4 inches deep in your firebox, and when fire has burned down and cooled, remove excess ashes. Leave an ash bed approximately 1" (25 mm) deep on the firebox bottom to help maintain a hot charcoal bed.

Disposal of Ashes

Ashes should be placed in a metal container with a tight fitting lid. The closed container of ashes should be placed outside on a non-combustible floor or on the ground, well away from all combustible materials, pending final disposal. If the ashes are disposed of by burial in soil or otherwise locally dispersed, they should be retained in closed container until all cinders have thoroughly cooled. Other waste should not be placed in this container.

Blower Operation

The blower is wired with a thermo switch that will turn on the blower automatically once the fireplace has reached an appropriate operating temperature.

It is also recommended that the blower be wired to a wall switch or dimmer switch for manual control. If the blower should ever need to be replaced, power to the blower can be shut off at the switch during replacement.

Baffle Removal

Baffle should only be removed when chimney is being cleaned.

DO NOT OPERATE WITH BAFFLE ASSEMBLY OR INSULATION REMOVED.

Removal

Remove retaining pin at the rear inside top of the firebox, just under the baffle. Lift baffle up and pull forward to disconnect from the supply tube. Tilt baffle sideways to drop down and remove from firebox. Inspect gasket between baffle and supply tube. If necessary, replace with gasket #SUMB.31396 available from your Pacific Energy dealer. Re-install baffle assembly in reverse order. Ensure that the two side pieces of insulation are set inside the side rails and tight against the baffle. If the insulation is damaged during removal, it should be replaced.

NOTE: AFTER YOU REMOVE THE BAFFLE, ALWAYS COVER THE BAFFLE AIR TUBE THAT PROVIDES AIR TO THE BAFFLE. THIS PREVENTS DEBRIS FALLING DOWN THE TUBE.

Secondary Air Box Cleaning

1. The secondary air box is located on the bottom rear of the woodstove and can be accessed by removing the access panel on the bottom of the firebox. Remove the bricks to expose the access panel, then remove the 8 screws holding the access panel.
 2. Remove the two screws securing the cover plate on the side face of the secondary air box and using a vacuum, suck out any debris.
 3. Replace the cover plate.
- * **MAKE SURE THE GASKET IS IN GOOD SHAPE AND POSITIONED CORRECTLY. IF IT IS DAMAGED THEN IT MUST BE REPLACED.**

Glass Cleaning

If glass becomes darkened through slow burning or poor wood, it can readily be cleaned with fireplace glass cleaner when the stove is cold. Never scrape with an object that might scratch the glass. The type and amount of deposit on the glass is a good indication of the flue pipe and chimney buildup. A light brown dusty deposit that is easily wiped off usually indicates good combustion and dry, well-seasoned wood and therefore relatively clean pipes and chimney. On the other hand, a black greasy deposit that is difficult to remove is a result of wet and green wood and too slow a burning rate. This heavy deposit is building up as quickly in the chimney.

Blower Replacement

1. The blower is located in the bottom rear compartment of the woodstove and can be accessed by removing the access panel on the bottom of the firebox. Remove the bricks to expose the access panel, then remove the 8 bolts or screws holding the access panel using a 7/16" socket or wrench(Fig. #1).
2. Loosen the hose clamp on the 3" flex vent at the air box towards the front of the woodstove and disconnect the flex vent. Gently push the flex vent clear of the access opening(Fig. #2 & #3).
3. Disconnect the wire lead of the blower from the electrical terminal block and the male/female connection to the Thermo Switch .
4. Remove the two wingnuts securing the blower mounting bracket(Fig. #4).
5. Gently lift the bracket and slide the blower towards the front of the woodstove.
6. Lift the blower up and out of the woodstove through the access opening.
7. Remove the nuts attaching the blower to the bracket and replace blower(Fig. #5).
8. Reverse the process to re-install blower.

FIG. #2

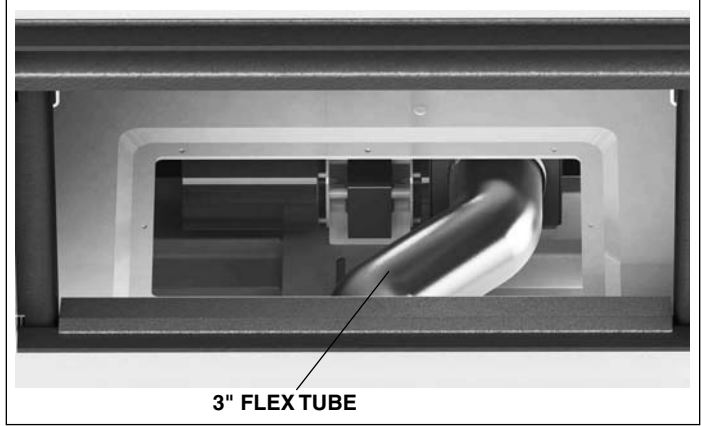

FIG. #3

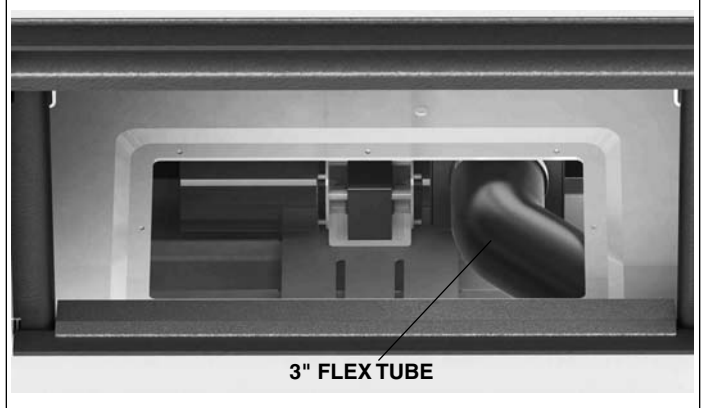

FIG. #1

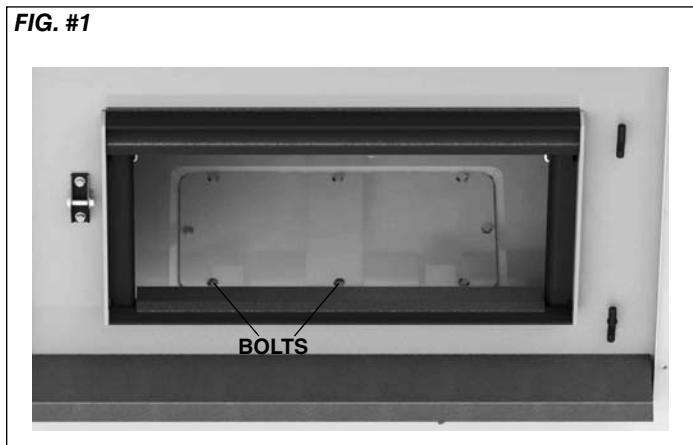

FIG. #4

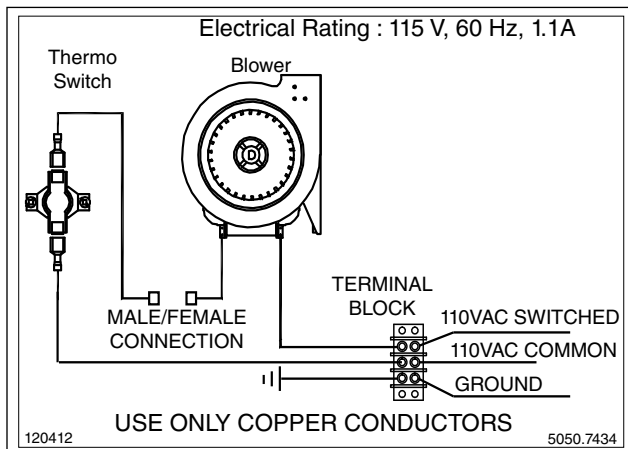
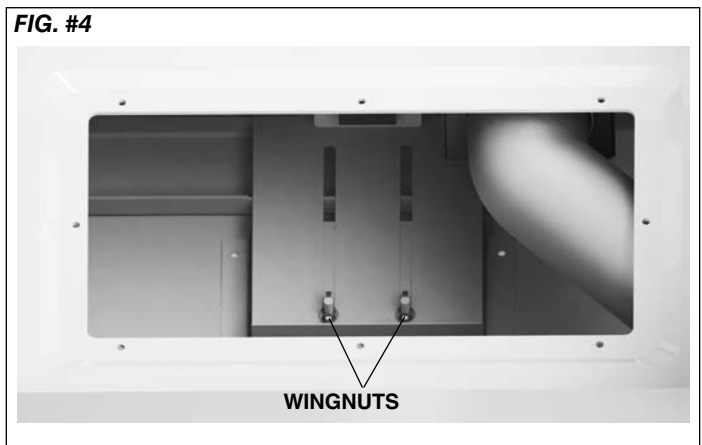
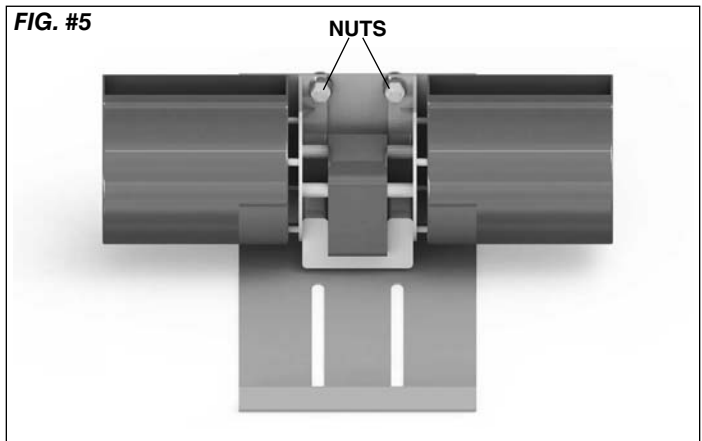

FIG. #5





Firebrick Installation

This package contains 19 full-size firebricks, as well as 3 various cut-size bricks.

With the woodstove in the upright position, install firebricks as follows:

- 1) Place the firebricks on the bottom of the unit first. Use a total of 9 full-size (A) and 1 cut brick (C).
- 2) Next install the rear firebricks, 4 full-size (A) bricks as shown.
- 3) Finally install 3 full-size bricks (A) and 1 cut firebrick (B) on each side as shown.

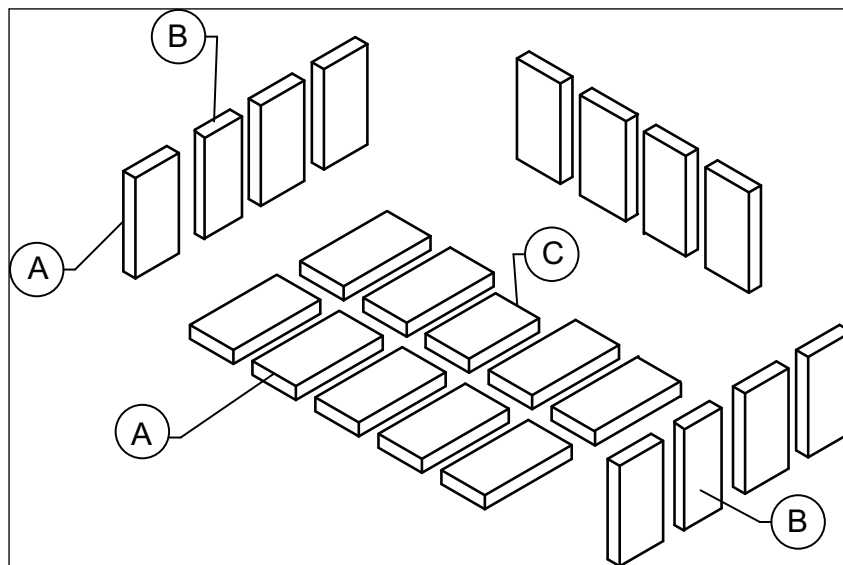

ITEM	SIZE		PART NUMBER
A	9" X 4 1/2" X 1 1/4"	(230 mm x 115 mm x 32 mm)	5096.99
B	9" X 3 1/2" X 1 1/4"	(102 mm x 115 mm x 32 mm)	3245.501
C	7 1/4" X 4 1/2" X 1 1/4"	(184 mm x 115 mm x 32 mm)	245.001

Fireplace Installation

Crate Removal

- 1) Carefully remove wood top and supports.
- 2) Remove the screws securing the fireplace to the pallet(4).
- 3) Remove from pallet bottom.

Warning: Under no circumstances is this heater to be installed in a makeshift or "temporary" manner. It may be fired only after the following conditions have been met.

- **DO NOT CONNECT THIS UNIT TO A CHIMNEY FLUE SERVING ANOTHER APPLIANCE.**

- **DO NOT INSTALL IN A SLEEPING ROOM.**

- The services of a competent or certified installer, (certified by the Wood Energy Technical Training program (WETT) - in Canada, Hearth Education Foundation (HEARTH) - in U.S.A.,) are strongly recommended.

Locating The FP30 Fireplace

The best location to install your fireplace is determined by considering the location of windows, doors, and the traffic flow in the room where the FP30 Fireplace is located, allowing space in front of the unit for the hearth extension and the mantel, and taking into consideration the location of the chimney. Ideally, you should choose a location where the chimney will pass through the house without cutting floor or roof joists.

Check the adequacy of the floor by first estimating the weight of the fireplace system. Next measure the area the fireplace will occupy. Note the floor construction and consult your local building code to determine if any additional support is needed. In most cases, no additional floor support is needed for the FP30 fireplace.

The FP30 fireplace may be installed directly on the floor or on a raised base. A minimum of 84" measured from the base of the appliance to the ceiling is required.

The FP30 fireplace may not be installed in a factory built fireplace unless tested with the fireplace.

Wind direction and magnitude can play a factor in the chimney performance. Therefore the chimney outlet position is important when locating the fireplace Fig.# 6.

The chimney should:

- Penetrate the highest part of the roof.
- Be installed as far as possible from roof offsets, trees or any other obstructions that may cause wind turbulence or back drafts in the chimney.
- The least amount of offsets (elbows) possible.

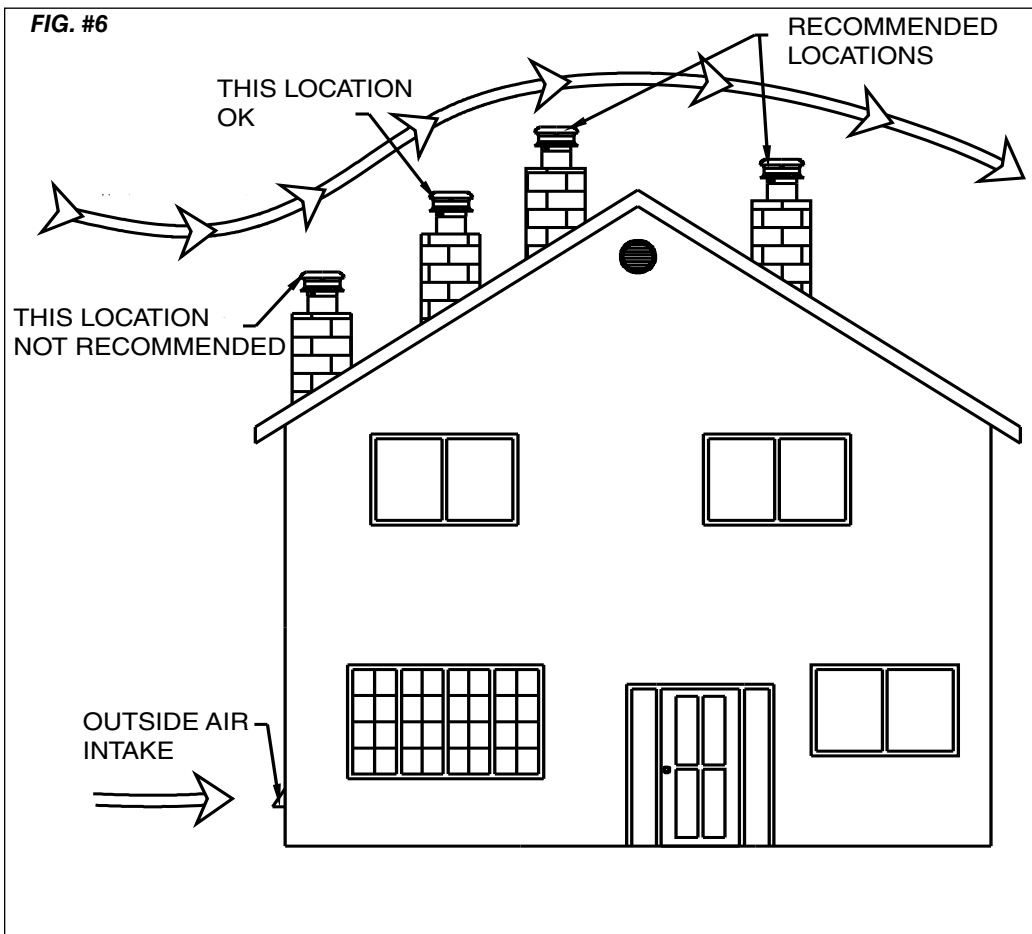

Clearances

This heater must be installed with a listed compatible chimney system listed on page 15.

Clearances to combustible surfaces and materials are shown on pages 12, 13 & 14.

Clearances may be reduced with various heat insulating materials. Consult local, National fire codes and authorities for approval.

Procedure:

Note: See "Combustion Air" section on page 17.

MAINTAIN CLEARANCES TO COMBUSTIBLES AS SPECIFIED IN THE INSTALLATION INSTRUCTIONS

CAUTION: THE STRUCTURAL INTEGRITY OF THE FLOOR, WALL AND CEILING/ROOF MUST BE MAINTAINED.

THE SPACE HEATER MUST BE CONNECTED TO A FACTORY-BUILT CHIMNEY CONFORMING TO CAN/ULC-S629 AND UL 103HT STANDARDS FOR 650C FACTORY-BUILT CHIMNEYS.

1. Position stove and floor protection in accordance with the clearances as stated on the label and in these installation instructions.
2. Mark the position for the hole for the chimney in the ceiling and roof by using a string and plumb-bob.
3. Check that the intended location will not interfere with floor joists, ceiling joists or rafters before proceeding further.
4. Assemble the framing kit as per instructions on page 11. Secure the framing kit to the top of the unit with three #8X1/2" sheet metal screws (Fig.#7) or use steel studs for the entire vertical section. The framing kit should be flush with the front of the fireplace. Frame in the fireplace in accordance with the framing clearances stated on page 12. Anchor the Framing kit to the wood framing on the sides and top.

FIG. #7

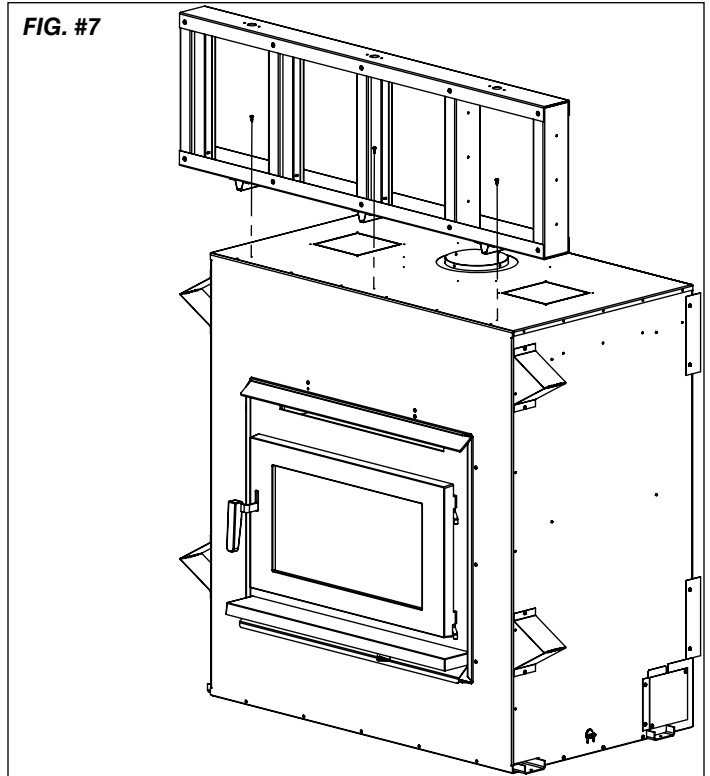

NOTE: Combustible materials cannot be used in the space directly above the fireplace. Do not fill the space above the fireplace with any material up to the ceiling. (except the wood framing)

The fireplace must not be in contact with any insulation or loose filling material. Cover the insulation with drywall panels around the fireplace.

Dimensions

FIG. #8

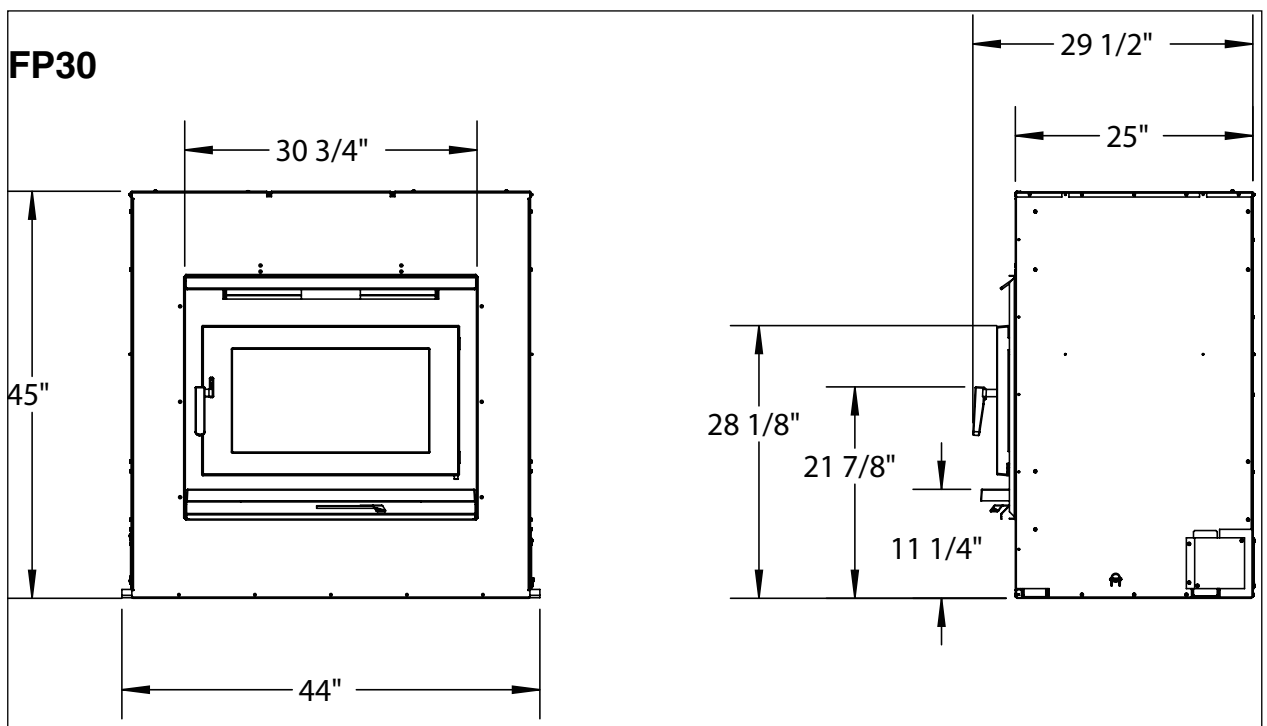

Minimum Framing Dimensions

FIG. #10

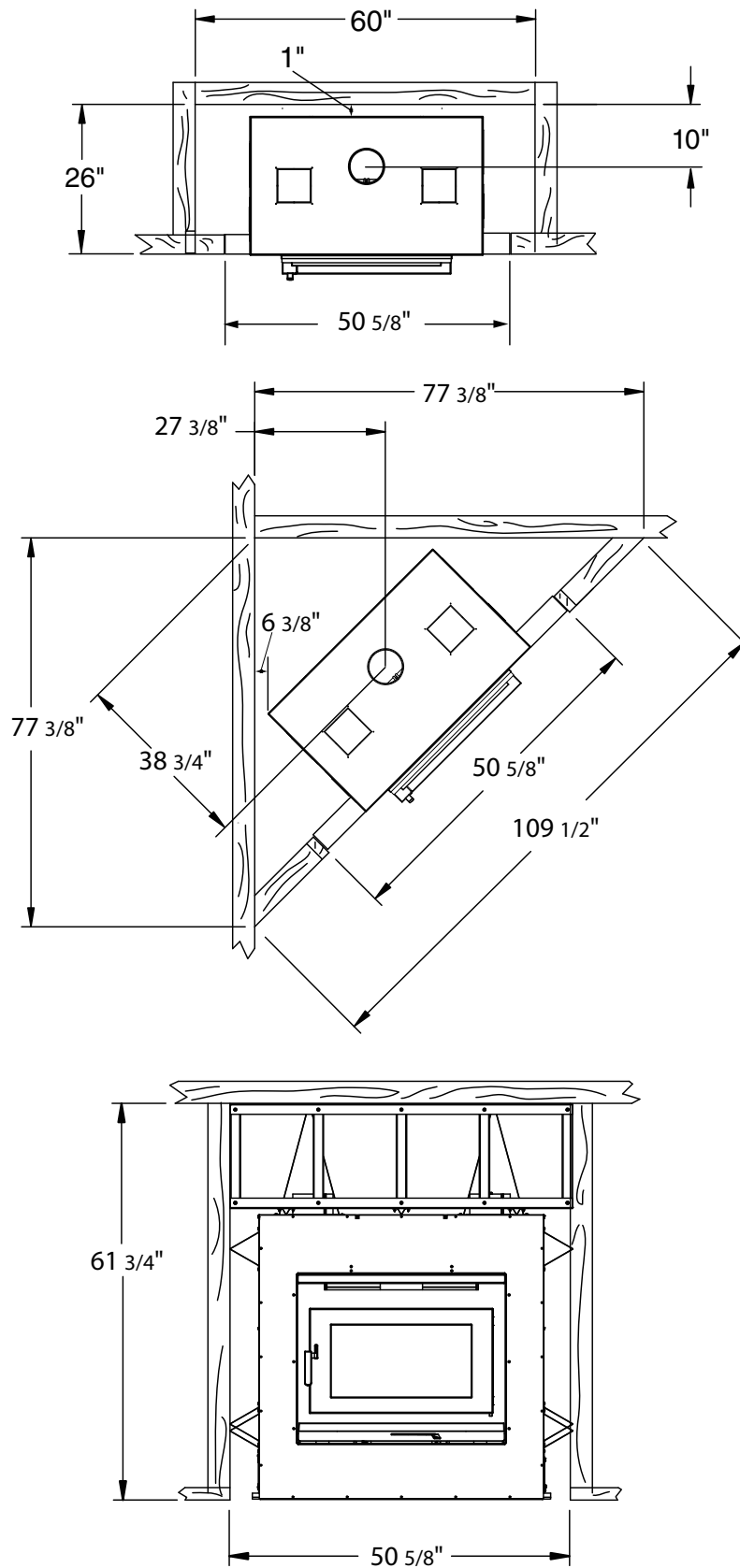

NOTE: THE FRAMING DIMENSIONS AROUND THE FIREPLACE MUST INCLUDE THE INNER DRYWALL BOARD.

Framing Kit Assembly

Each Kit Contains:

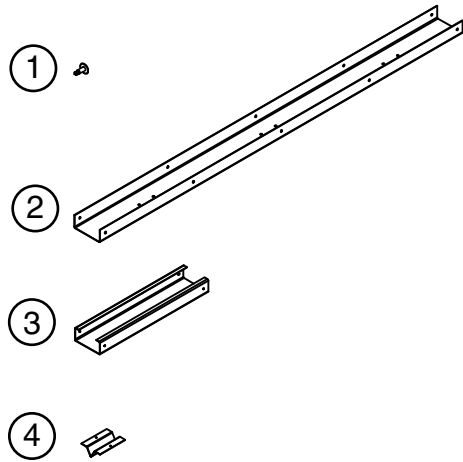

Item	Part #	Description	Qty.	
1	5049.9912	SCREW, TEKS #8 x 1/2"	Pkg 40	
2	7746	STUD, TOP/BOTTOM 50 1/2"L	2	
3	9093.22	STUD, CNTR SUPPORT SIDES, 15"L	5	
4	7747	FRAMING KIT LEG 3 1/2"L	3	

Assembly

- Lay out top/bottom studs (2) and center studs (5) on a large flat surface. (Fig #9)
- Using the screws provided (1), attach the framing kit legs(4) to the bottom stud (2).
- Next, attach each center support(3) to the bottom stud(2) and then attach the top stud(2) to the center supports(3).

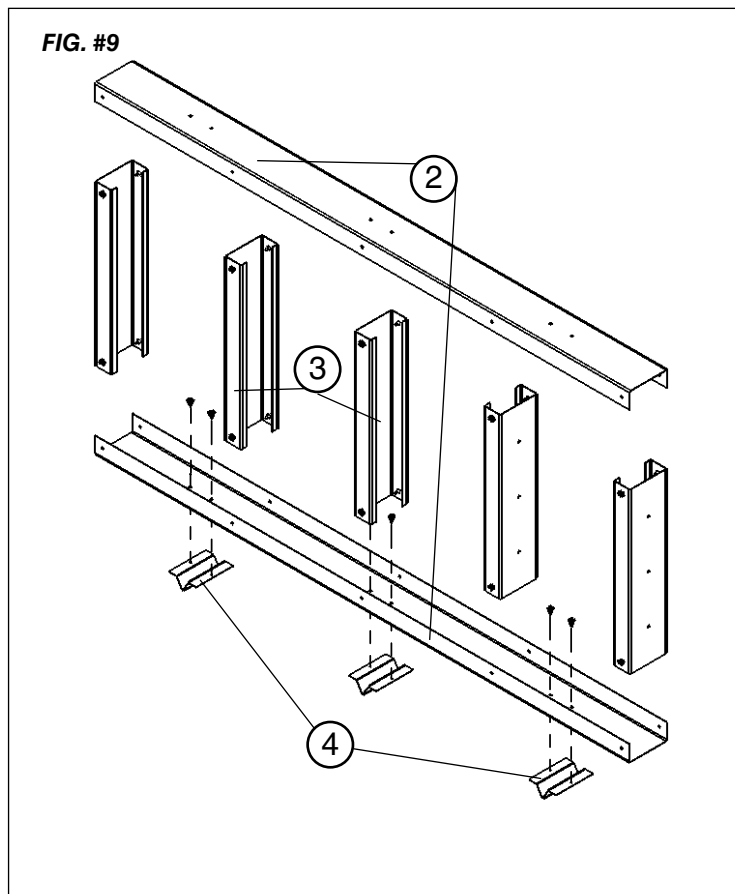

Minimum Clearances to Combustibles

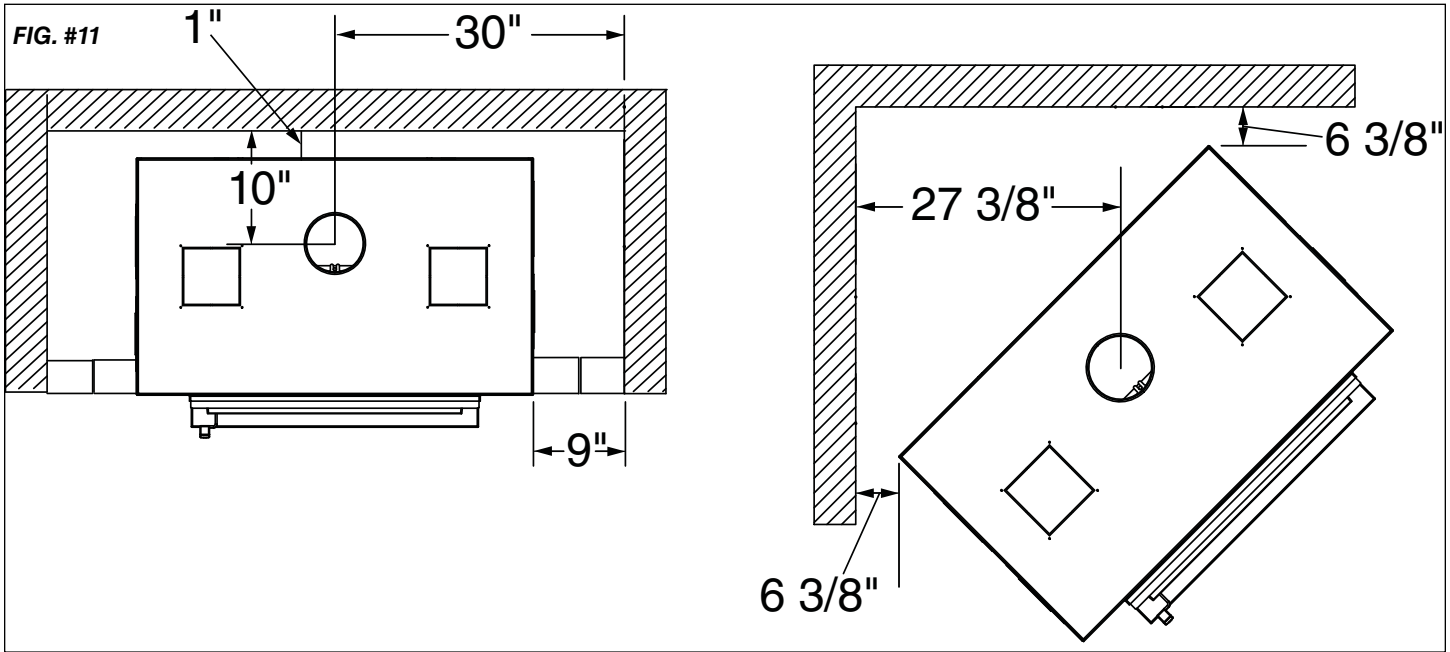
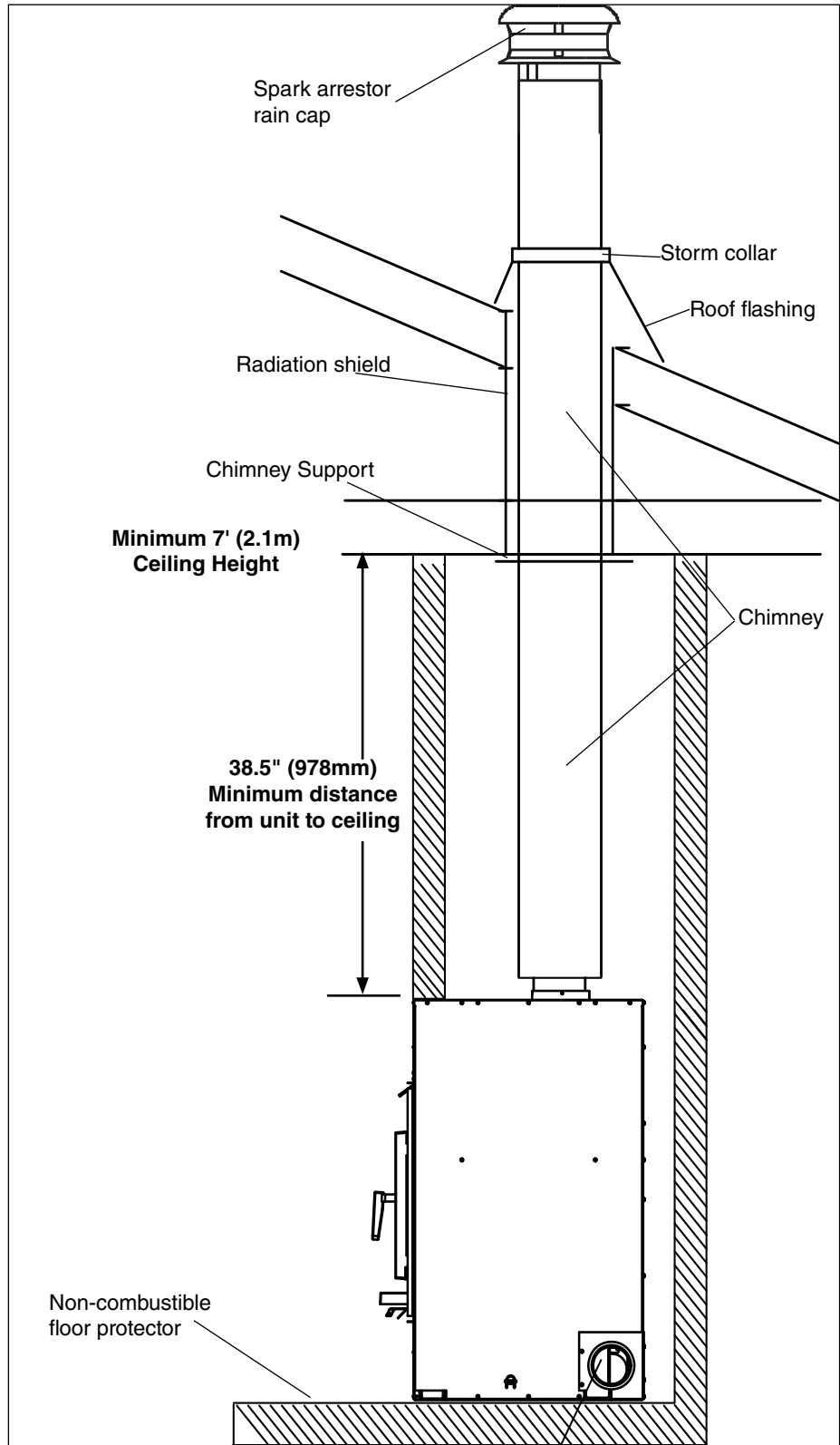

FIG. #12

The chimney may incorporate an offset. To do this safely, all sections of listed connector, offset elbows and chimney section must be screwed together by at least three sheet metal screws per joint. The chimney must be suitably supported by the chimney manufacturer's listed offset support. NOTE: Maximum unsupported chimney height is 25 feet(7.62m)



* 4" diameter combustion outside air inlet. One on either side of unit. A 4" outside air inlet is also on the left side of the unit for outside fan air. The combustion air inlets can be rotated to draw air from the rear of the unit if desired.

Chimney Installation

Listed Chimney and Chimney Connector

This appliance must be installed with a 6" (in Canada) ICC chimney system and any 6" chimney system (in U.S.A.) approved under the following standard: UL 103HT.

YOU MUST FOLLOW THE CHIMNEY MANUFACTURER'S INSTALLATION INSTRUCTIONS FOR INSTALLATION OF ALL CHIMNEY COMPONENTS.

MAINTAIN CLEARANCES TO COMBUSTIBLES AS SPECIFIED IN THE CHIMNEY MANUFACTURER'S INSTALLATION INSTRUCTIONS

USE APPROPRIATE SUPPORTS, CAPS, FLASHING AND SHIELDS IN ACCORDANCE WITH THE CHIMNEY MANUFACTURER'S INSTALLATION INSTRUCTIONS.

THE FOLLOWING INSTRUCTIONS ARE GENERAL GUIDELINES ONLY.

CAUTION: THE STRUCTURAL INTEGRITY OF THE FLOOR, WALL AND CEILING/ROOF MUST BE MAINTAINED.

NOTE: The FP30 can be installed with a minimum 15ft of chimney with or without offsets.

NOTE: Longer chimney lengths and different pitch flashings may be used. All other parts listed can be installed (see Figure 12, Page 14). Install all components to the chimney manufacturer's installation requirements. Consult your chimney supplier for installation advice.

1. After locating the desired location and framing in the fireplace, cut and frame square holes in all floors, ceilings, and roof that the chimney will pass through. Use a plumb bob to line up the holes. The chimney support is mounted to the framing.
2. Maintain a minimum 2" clearance between the chimney and any combustible materials. Do not fill the space with insulation or any other combustible material.
3. Install the pipe manufacturer's stove to chimney adapter by inserting it into the flue collar. Secure with 3 stainless steel screws. We recommend sealing the joint with stove cement
4. Assemble chimney sections so the finished length is resting on the manufacturer's adapter and protruding through the roof. Avoid having joints between ceiling and roof. It is required to secure connections with three (3) ½" (12 mm) metal screws.

5. Install radiation shields, firestops and all pieces necessary to prevent contact with combustible materials whenever passing through floors ceilings or attic spaces.
6. Install the roof support then assemble flashing and storm collar and be sure to maintain the vapour barrier at this point. (Seal securely.)
7. Attach rain cap and check flashing for leaks.
8. If the chimney extends more than 5' above the point of contact with the roof, then it must be secured using roof braces.

Chase Enclosure

NOTE: THE CHASE ENCLOSURE MUST HAVE A 30in² (194 cm²) AIR INLET. (IN U.S.A. AND CANADA) OTHERWISE, SERIOUS OVERHEATING OF THE CHASE MAY RESULT.

If the chimney runs up the outside of the residence, we recommend it be enclosed in a chase structure. The chase should be constructed in such a way that it is an extension of the home. It should be well insulated between the footings and the floor of the home to prevent heat loss. We also recommend to insulate the ceiling of the chase just as if it were in the attic space. This will prevent cold air from dropping down through the chase and into the room where the fireplace is installed. Some local codes require that the walls be insulated, vapor sealed and sheathed with a fire rated gypsum board. We strongly recommend this procedure for all installations to prevent cold drafts from originating in the fireplace enclosure. If you follow this procedure, we recommend that you do not insulate the wall above the front of the fireplace.

NOTE: Check local codes concerning installation requirements and restrictions in your area.

NOTE: FOR ALL CHIMNEYS, YOU MUST USE THE MANUFACTURER'S ADAPTER.

NOTE: Combustible materials cannot be used in the space directly above the fireplace. Do not fill the space above the fireplace with any material. (except the wood framing)

The fireplace must not be in contact with any insulation or loose filling material. Cover the insulation with drywall panels around the fireplace.

The Chase inlet is to be located a minimum 1-1/2 inch above the floor at suggested locations as depicted in Fig 24. It is not required to install a chase outlet but doing so can provide extra heat into the room the unit is in when gravity vents are ducted to other rooms.

Listed Chimney and Chimney Connector

This appliance must be installed with one of the following compatible chimney systems - All parts 6":

CANADA ONLY:	MANUFACTURER ICC	BRAND Excel	TYPE 1" Solid Pack.	INNER DIAMETER 6" (152mm)
USA ONLY:	Security	Secure Temp ASHT	1" Solid Pack	6" (152mm)
	Selkirk	Ultra-Temp	1" Solid Pack	6" (152mm)
	ICC	Excel	1" Solid Pack.	6" (152mm)
	Simpson Dura-Vent	DuraTech Class-A	1" Solid Pack.	6" (152mm)

Offsets

The chimney for the FP30 can be installed with a maximum of four 45° elbows(in Canada) and four 30° elbows(in U.S.A.) as shown in Fig. #13.

Installation:

1. Install the first elbow; turn it in the required direction. It is required to secure connections with three (3) #8 x ½" (12 mm) metal screws.
2. Install the necessary chimney lengths to achieve the required offset. Lock the chimney lengths together according to the chimney manufacturer's instructions. It is required to use three (3) #8 x ½" (12 mm) metal screws at every connection of the chimney. If the offset length is made of two (2) chimney lengths or more, many chimney manufacturers may require that you use an offset or roof support halfway up the offset. If penetrating a wall, install a wall radiation shield supplied by the chimney manufacturer and according to the manufacturers installation instructions.
3. Use another elbow to turn the chimney vertically, Secure the elbow.
4. Use a plumb bob to line up the centre of the hole. Cut a hole for the chimney in the ceiling/floor. Frame the hole as described on page 15.
5. From below, install a firestop supplied by the chimney manufacturer.
6. A support must be used on the first 15' section (4.6m).

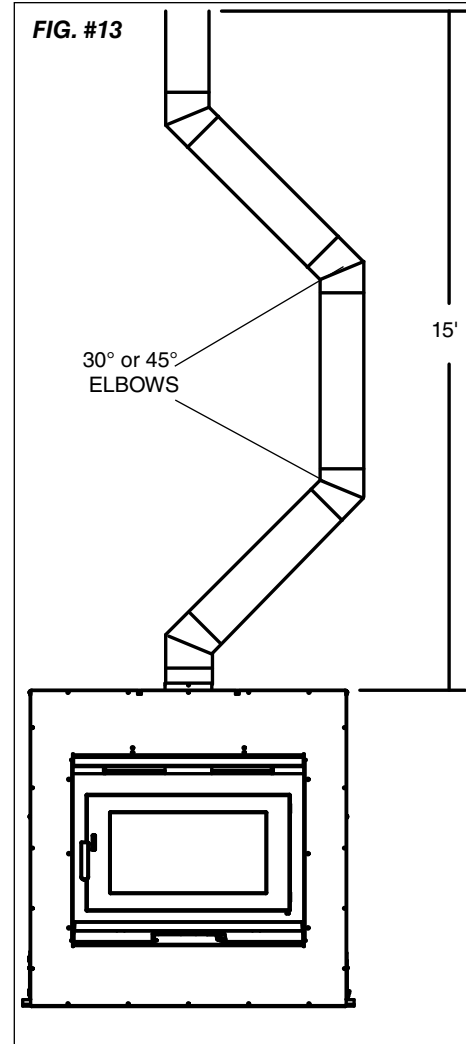

Table 1 Fireplace Clearances and Dimensions

A	Distance of combustible material from side, back standoffs and framing kit.	0" (0,0 mm)
B	Minimum distance of adjacent wall to side of fireplace.	30" (762mm)
C	Ceiling clearance: from the base of the fireplace to the ceiling.	7' (2.13m)
D	Minimum chimney height: minimum total chimney height from fireplace top to below the chimney rain cap.	15' (4.57m)
E	Recommended maximum chimney height (at sea level) from top of fireplace to rain cap.	35' (10.7m)
F	Maximum chimney height supported by fireplace.	25' (7.62m)
G	Minimum depth of non-combustible hearth extension: from the front of the fireplace.	18" (457mm)
H	Minimum width of floor protection from side of door opening(in U.S.A.) and from side of unit(in Canada).	8" (203 mm)

Combustion Air

Intake or combustion air can be supplied to the stove in one of two ways. Consult your local building code or CAN/CSA-B365, Installation Code for Solid-Fuel-Burning Appliances and Equipment before proceeding.

1. **Outside air supply** - Outside air may be drawn from either side of the stove.

To draw outside air, remove the cover plate on the side you wish to draw the air from and connect the outside air adapter provided (Fig. #14).

Outside Air Adapter

The adapter is only required if outside combustion air is used.

Installation:

Remove cover plate from the side of the unit closest to the exterior wall in which you will be connecting the outside air inlet. To change from side to rear inlets, remove the screws holding the corner plate to the air jacket. Gently pull corner plate from the unit and disconnect the flex vent, flip over the corner plate and reattach the flex vent. Reattach the corner plate to the air jacket. Place the adapter over the 4" round hole with the collar facing out and attach with screws previously removed with the cover plate.

Cut or drill a 4" diameter hole in the closest exterior wall or in the floor anywhere inside the chase. **Cover the hole with a 4" x 4" (100 mm x 100 mm), 20GA wire mesh minimum, rodent screen and staple/nail in place.** Provide water protection as required. Attach 4" venting (not supplied) to adapter

WARNING: This hole must get its air from the outdoors and be finished with an approved vent cap. The use of outside combustion air for residential installation requires the unit to be secured to the structure to prevent dislodging of the air duct. Check local building codes for instruction on sealing the vent cap at the penetration point of the building. The combustion air inlet ducts can not terminate in an attic space or garage.

2. **Room air supply** - Remove the cover plate from the front of the unit underneath the ashlip. The stove will now draw its air from the room through this opening and into the firebox intake. You must ensure the room has adequate air to operate the unit.

WARNING: This unit is not designed to be operated with the firing door open. In addition to the obvious hazard of sparks landing on combustibles, an open fire door will cause the heater to draw excess air from the living space and possibly cause suffocation.

CAUTION: The living space around the heater must be well ventilated with good air circulation. Anything that may cause a negative pressure can cause gases or fumes to be pulled into the living area. During extremely cold weather, and especially when burning at very slow rates, the upper parts of the exposed chimney may ice up, partially blocking the flue gases. If blockage occurs, flue gases may enter living space.

A typical outside air connection is shown in Fig. #15.

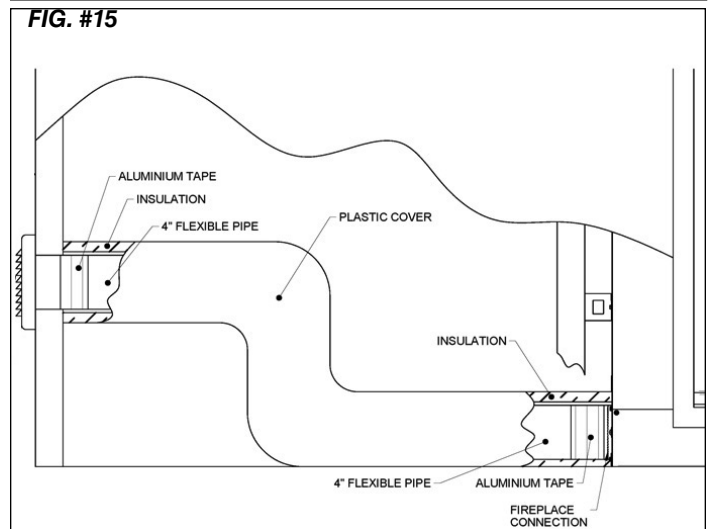
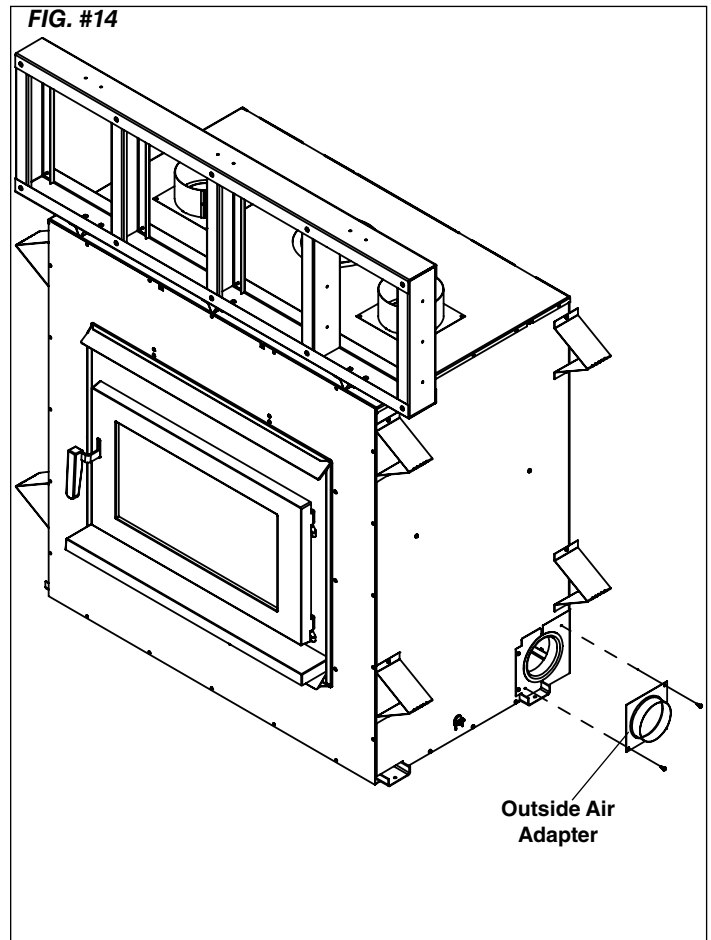

Floor Protector

The stove may be installed on a combustible floor provided non-combustible ember protection, such as tile, metal, brick, etc., is used in front of the unit as per Fig. #16 & #17. This protection must extend as follows:

In Canada: 18" (457 mm) on the firing side and 8" to the sides. See Figure #16, below.

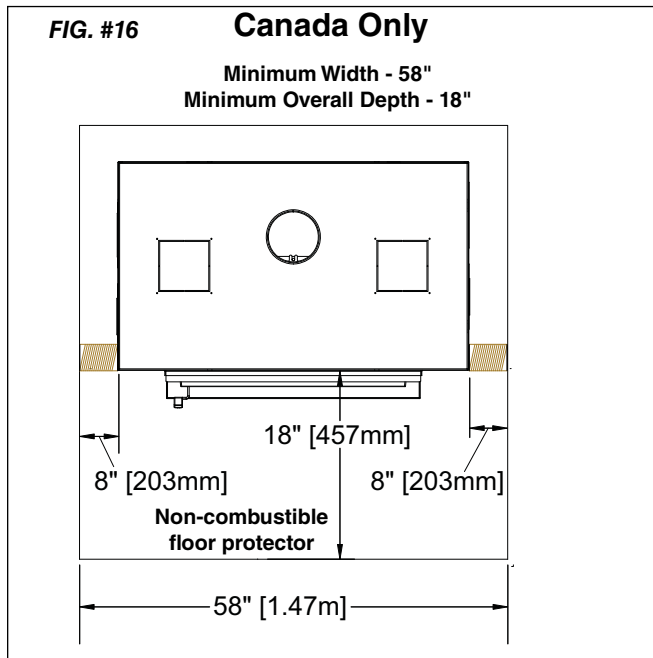

In U.S.A: 18" (457 mm) to the front and 8" to the sides of the fuel loading door opening. See Figure #17, below.

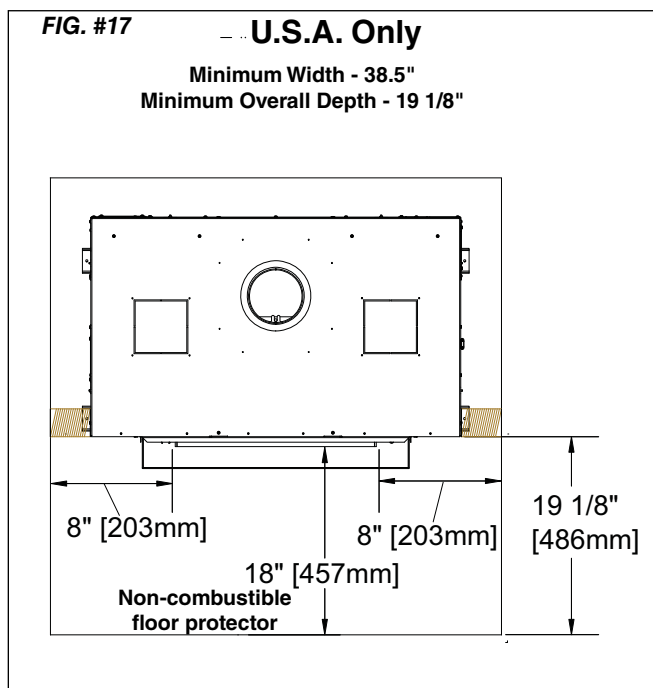

Safety Strip

The floor between the fireplace and the hearth extension/ember protection must be protected with a safety metal strip.

One half of the metal strip must be under the fireplace front and the other half must extend onto the floor and under the hearth extension/ember protection as shown in Fig. #18.

FIG. #18

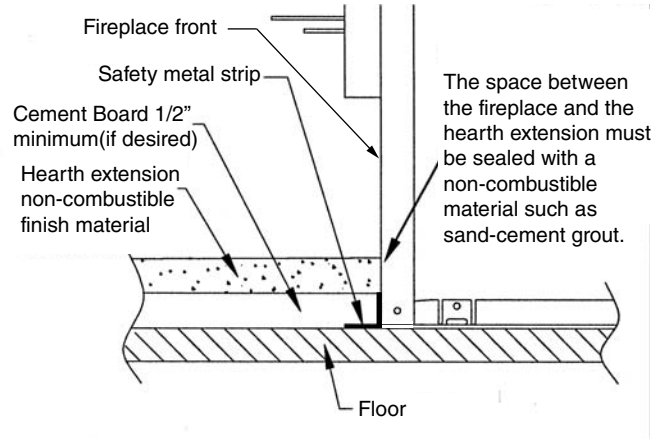

Blower Wiring

The FP30 must be connected 120 VAC house hold electrical system.

It is recommended to also connect the unit to a wall switch or fan speed controller.

Insert the Nomex 14/2 wire, or equivalent, into the unit through the strain relief located on the right hand side of the fireplace casing.

Connect the wiring as shown in the wiring diagram below to the terminal block located in the bottom of the unit. See section (Blower Repair) on Page 7. All electrical connections should be performed by a certified/licensed electrician.

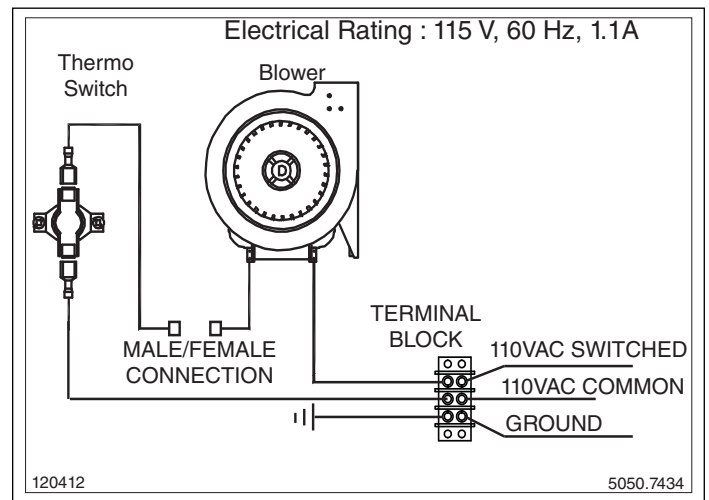

Remote Heat Duct Installation

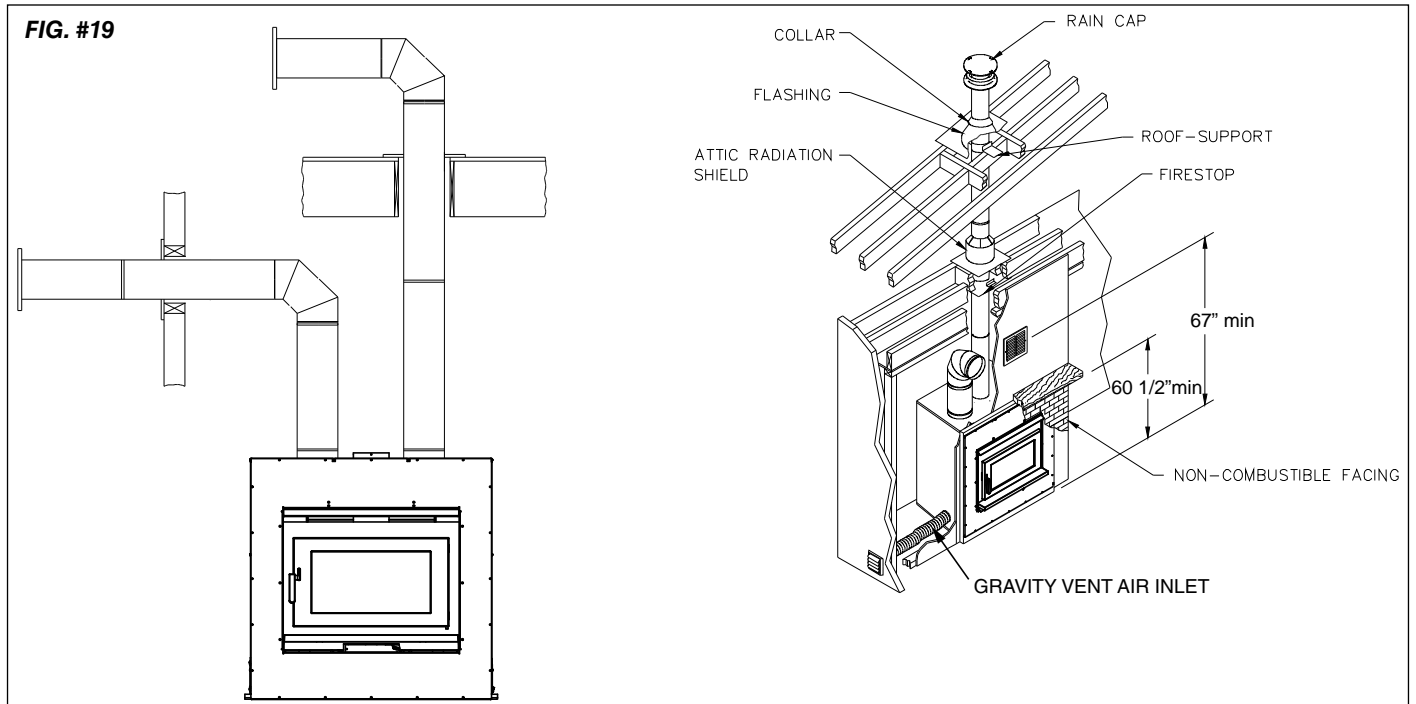

**IN U.S.A., A MINIMUM OF ONE REMOTE GRAVITY HEAT DUCT KIT MUST BE INSTALLED WITH THE FP30.
PART# FP30.GVKIT**

INSTALLATION:

1. Using a pair of tin snips, cut away the square section blocking the heat duct openings and cut out insulation (Fig. #20).
2. Attach the heat duct adapter/s with the screws provided in the FP30.GVKIT (Fig. #20).

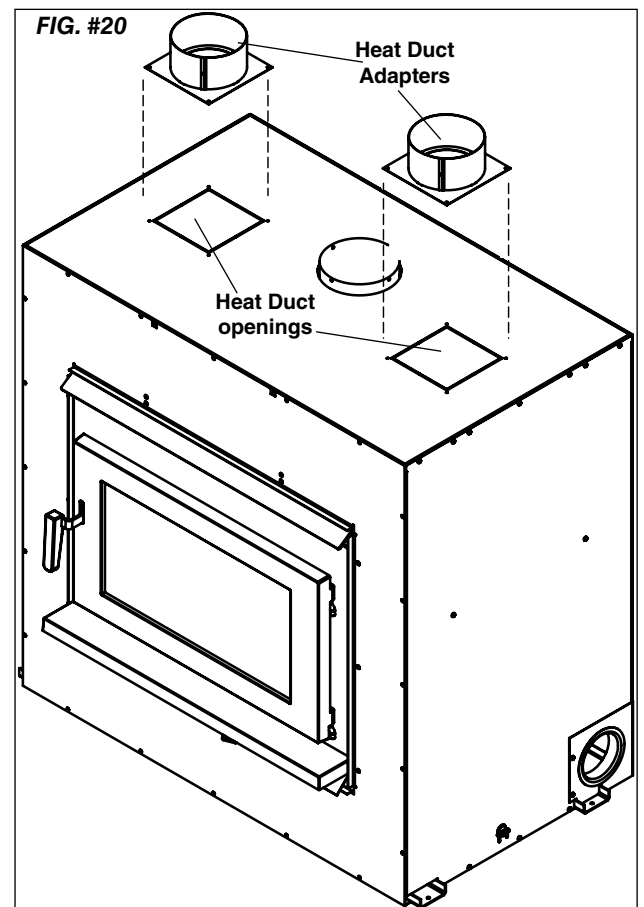

3. Locate and cut a 11 1/4" X 9 3/4" opening in the wall or facing material being sure to maintain structural integrity. Position the pre-assembled wall outlet in the hole and secure with two screws(Fig.#21).
4. The outlet must be a minimum 67" off the floor and a minimum 12" to the ceiling.
5. Connect Type "B" 6" venting(sold separately) to the adapter/s and run in accordance with the diagram in Fig. #1 and after bending the securing tabs inwards, insert the vent pipe approximately 1/2" into the opening in the wall outlet and secure to the outlet with two #8 X 1/2' Tek screws. Cover with outlet screen provided or one of equal outlet area.
6. Maintain clearances to combustibles as described in the venting manufacturer's specifications and use the manufacturer's required radiation shields and/or firestop if passing through a floor or wall.
7. A maximum 20' total run including 2 - 90° elbow is allowed. The venting should only run horizontally or up, never in a downward direction.
8. If running two gravity vents and/or if your facing material is more than 1/2" thick(Max. 4"), connect additional room air to the 6" Gravity Vent air inlet on the left side of the fireplace casing using the adapter provided(Fig. #23).

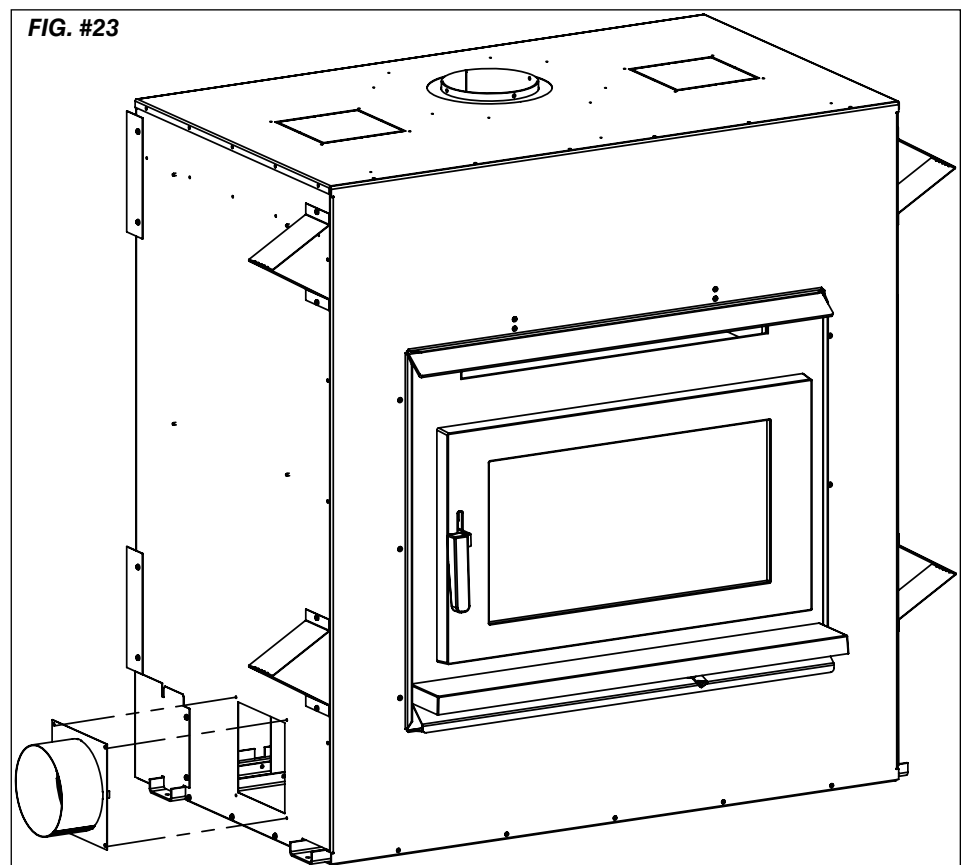
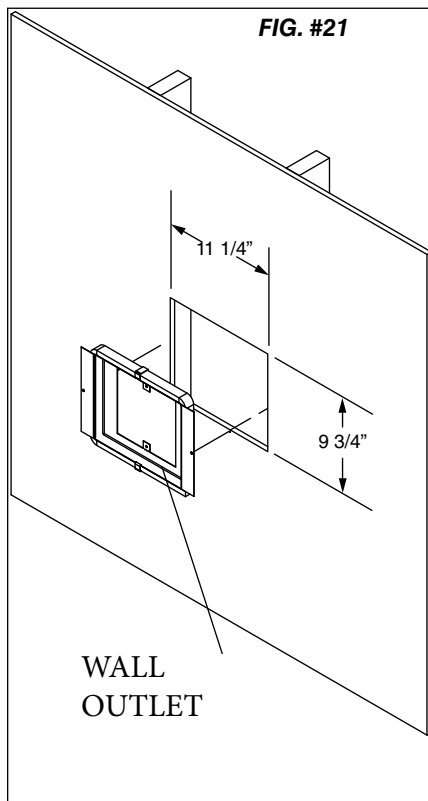
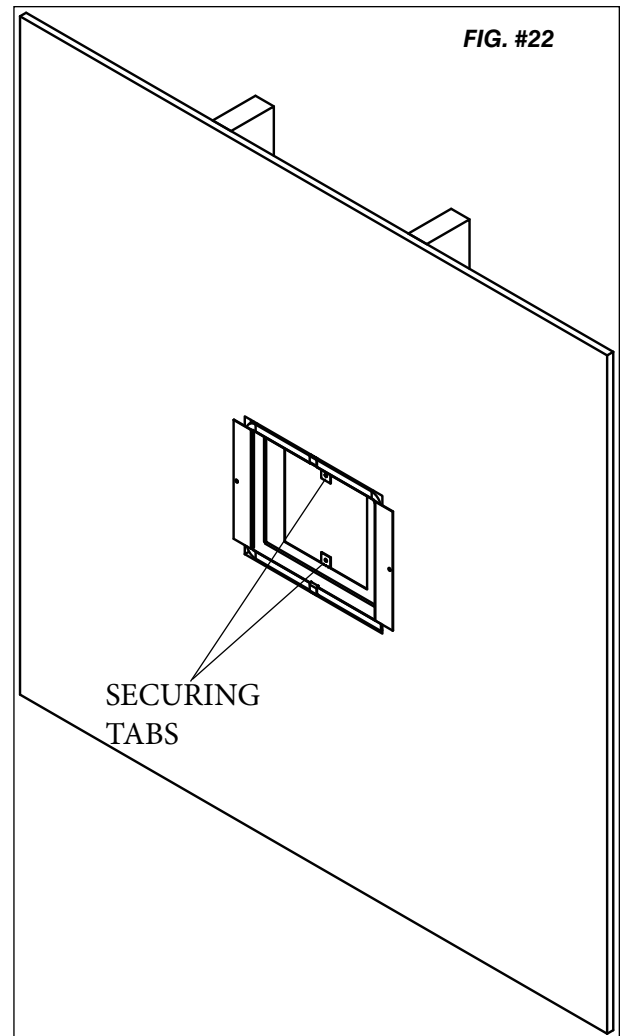

Facing and Air Inlet

Cement Board Installation

The front facing area of the FP30 must be covered with non-combustible cement board as shown in Fig.#24 and #25 prior to applying any finishing material.

The cement board can be attached to the framing and to the front of the unit outside of the dimensioned area shown by the dotted line in Fig.#24.

Use the manufacturer's suggested fasteners to attach the cement board and install as recommended.

Tape and mud the joints as per the board manufacturer's recommendations.

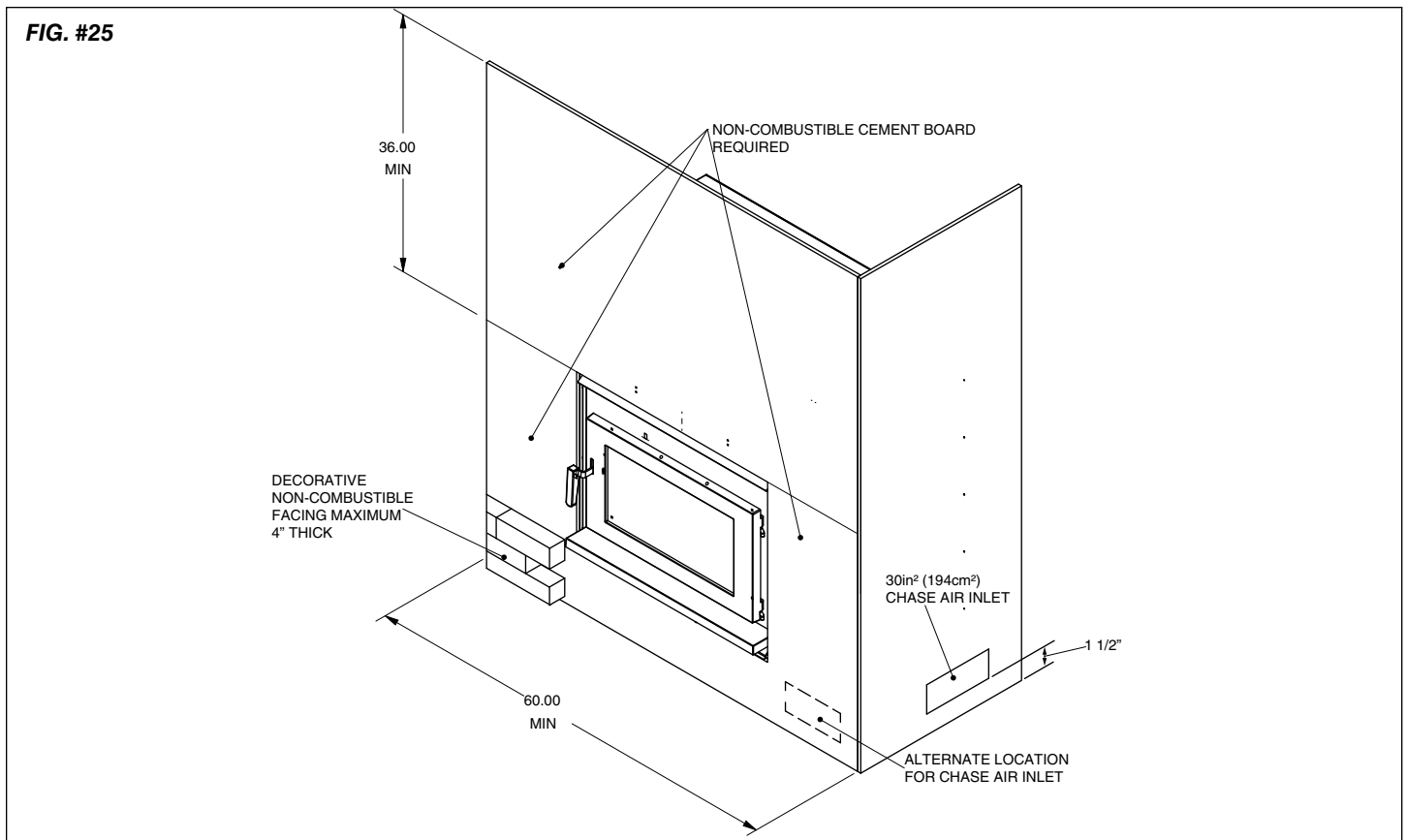
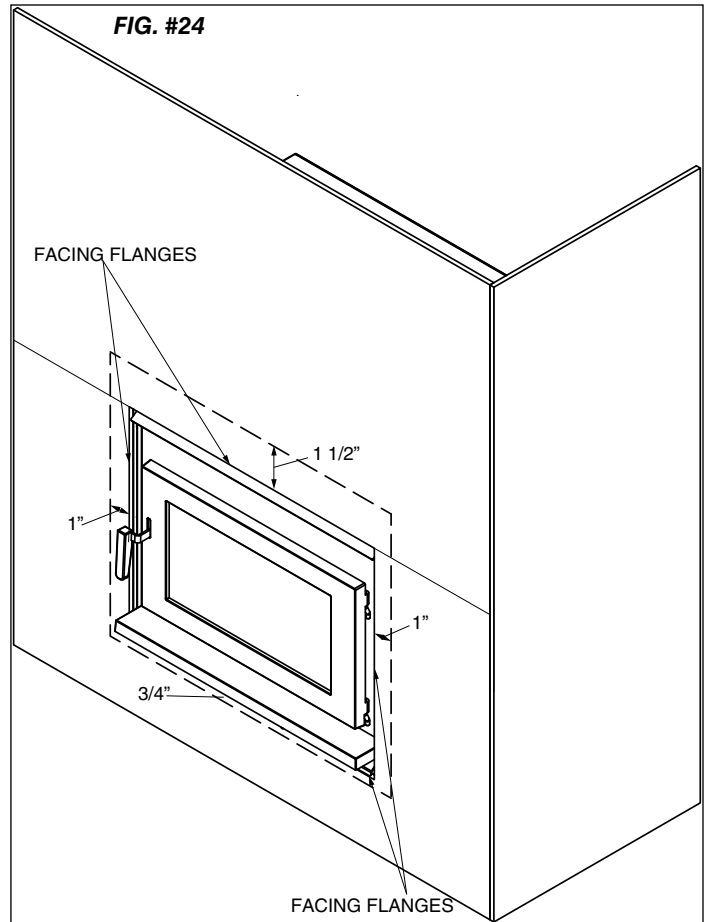

Mantel Clearances

FIG. #26

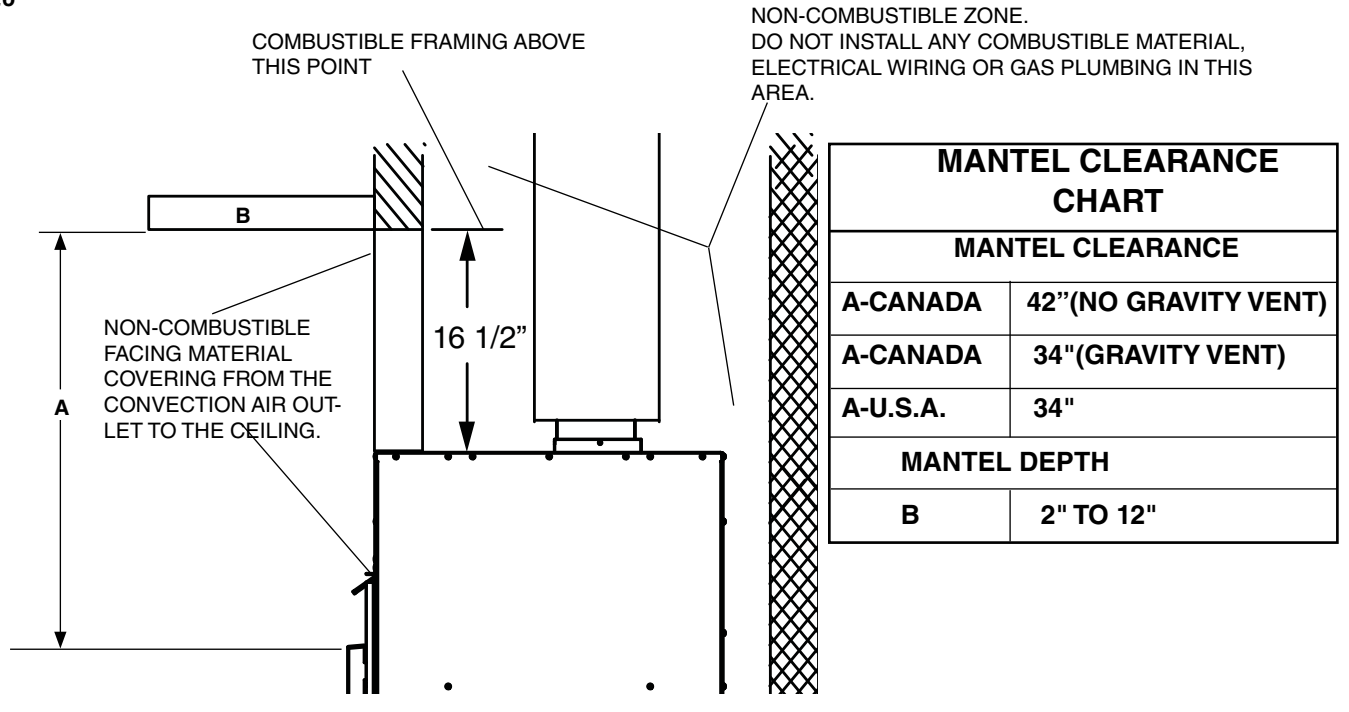

Appendix A

Troubleshooting

Problem	Cause	Cure
Glass is Dirty	1. Wood is wet	- Use dry wood
	2. Turning down air control or damper too soon	- Do not turn down until a) there is a good bed of coals b) the wood is charred
	3. Draft too low	- Improper chimney height and / or diameter - Chimney plugged or restricted, inspect and clean - Provide outside air for combustion
	4. Door gasket leakage	- Replace gasket - Check latch
Excessive Creosote Buildup - See 1,2,3, above.		
Low Heat Output	1. Wood is wet	- Use dry wood
	2. Fire too small	- Build a larger fire
	3. Draft too low	- Chimney plugged or restricted, inspect and clean
Won't Burn Overnight	1. Air control is set too high	- Set control lower
	2. Not enough wood	- Unsplit wood is preferred for overnight burns
	3. Draft too high	- Excessive chimney height and/or diameter
Stove Won't Burn	1. Combustion air supply blocked	- Check outside air supply for obstruction - Check that room air cover is removed
	2. Draft too low	- Chimney plugged or restricted, inspect and clean - Chimney oversized or otherwise unsuitable, consult Dealer

Understanding & Operating Your Pacific Energy Stove

The Pacific Energy line of woodstoves is a culmination of years of research and development. Designed to be efficient, clean-burning and user-friendly, this heater will give you years of warm service. However, a knowledgeable operator is still the most important factor for maximum performance and part of this is understanding the basic functions of this design.

Traditional wood stoves had a basic combustion system which allowed a considerable amount of heat energy to escape up the chimney as unburned gases and particulates (smoke). Pacific Energy has designed a system that solves the problem by burning the smoke and releasing the additional heat to the room.

This system has two critical design features:

1. Above fire secondary air injection:

The hollow "air baffle" injects super-heated secondary air just above the load. With the stove at the proper operating temperature, this will create a secondary flame that will be evident for approximately 1/3 of the total burn time.

2. High mass and thermal insulation:

The high mass (weight) acts as a heat storage and the thermal insulation keeps the combustion zone hot. Active flaming takes place during the first part of the burn. During this stage, heat is stored in the mass of the unit and is later released slowly and evenly. As wood chars, active flaming will diminish. This clean charcoal burning stage will last for a considerable length of time and refuelling should be avoided until the charcoal base has become quite small.

OPERATING TIPS

1. Always use dry, seasoned firewood, up to 20" long. Load wood endwise, a mixture of large and small pieces, on top of a good ash base (1" minimum).
2. Operate on a medium to high setting, for up to 1 hour from cold start. After the initial warm up period, refuel and leave the air control on a medium setting for 5 to 10 minutes more and then set the air control to the desired position.
3. If a slow burn is desired, set the air control to low. Active secondary burning should be present above the wood load. If it is not present or goes out shortly after, proper operating temperature has not been reached and the stove needs additional warm up time.

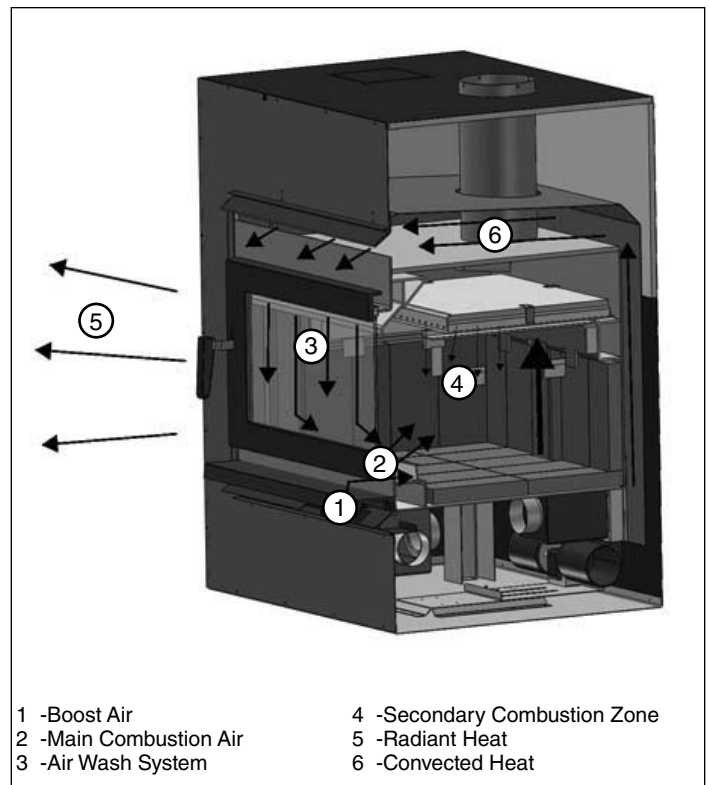

Replacement Parts

ITEM	DESCRIPTION	PART NO.
1	Inlet Air Shield	7719.5
2	Cast Ash Lip	ALIP.50374753
3	Blower	FP30.BLOW
4	Firebrick Set	BRIC.FP30
5	Door Gasket	FP30.DGKIT
6	Glass Retainer Set (4 pc.)	FP30.7748
7	Replacement Glass (c/w Tape)	FP30.GLKIT
8	Door Casting	5035.0221
9	Door Handle Assembly	FP30.50384
10	Replacement Baffle Kit	SUMB.BAFKIT
10a	Baffle (not sold separately)	SUMB.BAFF
10b	Side Insulation	5068.732.C
11	Brick Rails (2pc. Required)	SUMM.RAILSET
12	Baffle Pin	SSER.125001
13	Baffle Gasket	SUMB.31396
14	Flame Shield (c/w Bolt and Nut)	SUMB.31155
15	Door Catch	FP30.7763
*16	Gravity Heat Duct kit	FP30.GVKIT
*17	Outside Air Adapter	FP30.7745
*18	Access Cover Gasket	5068.81016
*19	Gravity Vent Adapter	FP30.9128

*NOT SHOWN

All parts may be ordered from your nearest Pacific Energy dealer. Contact Pacific Energy for the location of the dealer nearest you.

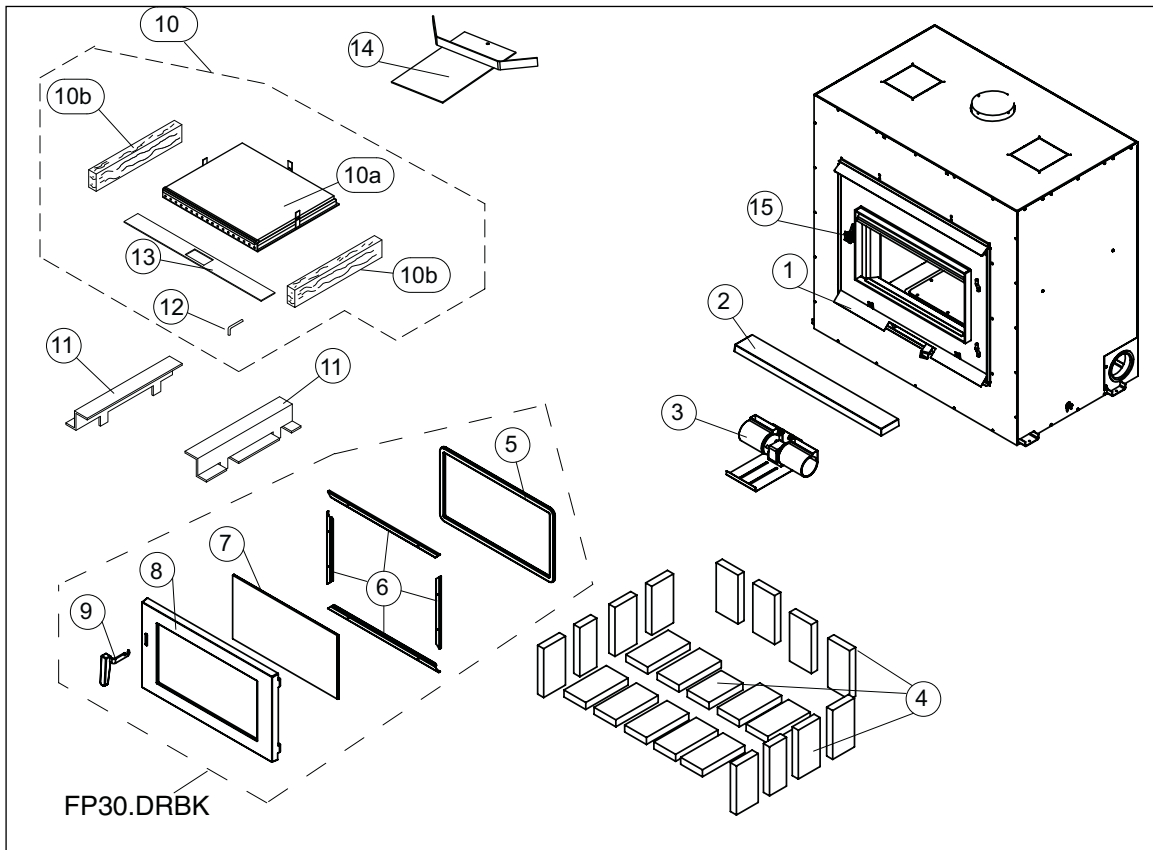

Label

Label Location

The rating label is located beneath the firebox on the casing floor and can be viewed by removing the access cover in the bottom of the firebox. There is an additional clearances label on the right side, of the fireplace casing.

RATING LABEL



CERTIFIED FOR CANADA AND U.S.A. LISTED FACTORY BUILT FIREPLACE. CERTIFIED TO ULC S610-M87 AND CONFORMS TO UL 127-2011/ FOYER PRÉFABRIQUÉ HOMOLOGUÉ / CERTIFIÉ POUR UTILISATION AU CANADA ET AUX É.-U. TESTÉ SELON ULC S610-M87 ET UL 127-2011.

SN-601

DO NOT REMOVE THIS LABEL/ NE RETIREZ PAS CETTE

SERIES/SÉRIE: A MODEL/ MODÈLE: FP30

- INSTALL AND USE IN ACCORDANCE WITH THE INSTALLATION AND OPERATING INSTRUCTIONS SUPPLIED WITH THE APPLIANCE. • AREAS OF THE FIREPLACE INCORPORATING WARM OR COLD AIR DUCTS SHALL BE ENCLOSED IN ACCORDANCE WITH THE INSTALLATION AND OPERATING INSTRUCTIONS SUPPLIED WITH THE APPLIANCE.
- CONTACT LOCAL BUILDING OR FIRE OFFICIALS ABOUT RESTRICTIONS, INSTALLATION PERMIT AND INSPECTION IN YOUR AREA. • DO NOT CONNECT THIS UNIT TO A CHIMNEY FLUE SERVING ANOTHER APPLIANCE
- DO NOT OBSTRUCT THE OPENINGS IN FRONT OF THE FIREPLACE OR OTHERWISE RESTRICT SUPPLY AIR NECESSARY FOR NORMAL FIREPLACE OPERATION AS SPECIFIED IN INSTALLATION AND OPERATING INSTRUCTIONS SUPPLIED WITH THE APPLIANCE. INADEQUATE AIR SUPPLY FOR COMBUSTION, VENTILATION AND DILUTION MAY RESULT IN DANGEROUS OPERATION OF THIS AND OTHER APPLIANCES.
- SEE LOCAL BUILDING CODE AND MANUFACTURER'S INSTRUCTIONS FOR PRECAUTIONS REQUIRED WHEN PASSING A CHIMNEY THROUGH A COMBUSTIBLE WALL OR CEILING. CHIMNEY SYSTEM MUST BE LISTED TO: IN CANADA - USE ONLY ICC EXCEL CHIMNEY LISTED TO ULC-S-629, IN USA - UL-103 HT LISTED CHIMNEY
- OPTIONAL COMPONENTS: FRESH AIR KIT, GRAVITY HEAT DUCT KIT PART# FP30.GVKIT.
- OPERATE ONLY WITH FEED DOOR CLOSED. OPEN TO FEED FIRE ONLY.
- FOR SOLID WOOD FUEL ONLY. • BLOWER ELECTRICAL RATING 115V, 60HZ, 1.0AMP • REPLACE GLASS ONLY WITH 5mm CERAMIC GLASS.
- DO NOT USE OR INSTALL COMPONENTS OR PRODUCTS NOT SPECIFIED IN PACIFIC ENERGY INSTALLATION INSTRUCTIONS. DO NOT USE A FIREPLACE INSERT OR OTHER PRODUCTS NOT SPECIFIED FOR USE WITH THIS PRODUCT.
- THIS FIREPLACE HAS NOT BEEN TESTED WITH AN UNVENTED GAS LOG SET. TO REDUCE RISK OF FIRE OR INJURY, DO NOT INSTALL AN UNVENTED GAS LOG SET INTO FIREPLACE.

MINIMUM CLEARANCES TO COMBUSTIBLE MATERIALS/ DÉGAGEMENTS MINIMUMS AUX MATÉRIAUX COMBUSTIBLES

A. CHASE ENCLOSURE WIDTH/ LARGEUR DE CLÔTURE DE POURSUITE	60 in. / 1.52 m
B. BACKWALL TO CONNECTOR/ MUR ARR. AU TUYAU de RAC.	10 in./254 mm
C. BACKWALL TO UNIT/ MUR ARRIÈRE AU FOYER	1 in. / 25 mm
D. FRAMING OPENING/ OUVERTURE DE CADRAGE	51 in /1.3 m
E. CORNER TO CONNECTOR/ COIN AU TUYAU de RACCOR.	39 in./991 mm
F. SIDEWALL TO CONNECTOR/ MUR LAT. au TUYAU de RAC.	28 in./711 mm
G. NON-COMBUSTIBLES ONLY ABOVE UNIT TO CEILING/ NON-COMBUSTIBLES SEULEMENT AU-DESSUS FOYER A PLAFOND	18 in. / 457 mm
H. TOP OF DOOR TO MANTEL/ HAUT DE PORTE AU MANTEAU	***
J. CEILING TO UNIT/ DU PLAFOND AU FOYER	26 in. / 660 mm
K. FLOOR PROTECTION FROM FRONT OF UNIT/ PROTECTEUR de PLANCHER À L'AVANT DU FOYER	18 in. / 457 mm
K. FLOOR PROTECTION TO SIDE OF UNIT/ PROTECTEUR de PLANCHER AU CÔTÉ DU FOYER	8 in./203 mm
CLEARANCES TO ALL STANDOFFS/ DÉGAGEMENTS	0 in. / 0 mm

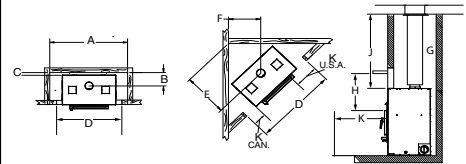

*** IN CANADA: "H" IS 42"(1.07m) WITHOUT A GRAVITY VENT INSTALLED AND 34"(864mm) WITH A GRAVITY VENT INSTALLED. IN THE U.S.A.: "H" IS 34"(864mm)

IN CANADA: "K" IS FROM THE SIDE FACING FLANGE/AU CANADA : «K» EST MESURÉ À PARTIR DE LA FAÇADE LATÉRALE DU FOYER./IN U.S.A : "K" IS FROM THE SIDE OF THE FIRING DOOR OPENING/AUX ÉTATS-UNIS : «K» EST MESURÉ À PARTIR DU BORD DE L'OUVERTURE DE LA PORTE DE CHARGEMENT.

LE SYSTÈME DE CHEMINÉE DOIT ÊTRE HOMOLOGUÉ COMME SUIV : AU CANADA - CHEMINÉE HOMOLOGUÉE ULC-S-629, ICC (INDUSTRIAL CHIMNEY COMPANY). AUX ÉTATS-UNIS - CHEMINÉE HOMOLOGUÉE UL-103 HT.

- INSTALLEZ ET UTILISEZ SELON LES INSTRUCTIONS D'INSTALLATION ET D'UTILISATION FOURNIES AVEC LE FOYER.
- LES PARTIES DU FOYER INCORPORANT DES CONDUITS CHAUDS OU FROIDS DOIVENT ÊTRE ENCHÂSSÉES, CONFORMÉMENT AUX INSTRUCTIONS D'INSTALLATION ET D'UTILISATION FOURNIES AVEC LE FOYER.
- CONTACTEZ LES AGENTS LOCAUX DU CODE DU BÂTIMENT OU DU SERVICE INCENDIE POUR LES RESTRICTIONS, PERMIS D'INSTALLATION ET EXIGENCES D'INSPECTION DANS VOTRE RÉGION.
- NE RACCORDEZ PAS CE FOYER À UN CONDUIT DE CHEMINÉE DESSERVANT UN AUTRE APPAREIL
- NE PAS OBSTRUER PAS LES OUVERTURES DEVANT LE FOYER, NI RESTREINDRE L'ALIMENTATION D'AIR NÉCESSAIRE POUR LE FONCTIONNEMENT NORMAL DU FOYER, TEL QUE SPÉCIFIÉ DANS LES INSTRUCTIONS D'INSTALLATION ET D'UTILISATION FOURNIES AVEC L'APPAREIL. LA PROVISION INADEQUATE D'AIR POUR COMBUSTION, MAI DE VENTILATION ET DILUTION A POUR RESULTAT L'OPERATION DANGEREUSE DE CECI ET AUTRES APPAREILS.
- VOIR LE CODE DU BÂTIMENT LOCAL ET LES INSTRUCTIONS DU FABRICANT, POUR LES PRÉCAUTIONS EXIGÉES LORSQU'UNE CHEMINÉE TRAVERSE UN MUR OU PLAFOND EN MATÉRIAUX COMBUSTIBLES.
- COMPOSANTS OPTIONNELS: KIT DE PRISE D'AIR, KIT DE CONDUITS DE DISTRIBUTION DE CHALEUR (PIÈCE no FP30.GVKIT).
- UTILISEZ LES COMPOSANTS SPÉCIFIÉS DANS LES INSTRUCTIONS D'INSTALLATION DE PACIFIC ENERGY.
- UTILISEZ SEULEMENT AVEC LA PORTE DE CHARGEMENT FERMÉE. NE L'OUVREZ QUE POUR ALIMENTER LE FEU.
- POUR COMBUSTIBLE SOLIDE SEULEMENT.
- REMPLACEZ LA VITRE SEULEMENT PAR UNE VITRE EN CÉRAMIQUE.
- LA SOUFFLERIE CLASSEMENT ELECTRIQUE 115V, 60 Hz, 1.0AMP
- CETTE CHEMINÉE n'A pas ETE ESSAYEE AVEC UN UNVENTED JOURNAL DE GAZ A REGLE. POUR REDUIRE LE RISQUE DE FEU OU BLESSURE, LE PAS INSTALLE UN UNVENTED JOURNAL DE GAZ A REGLE DANS CHEMINÉE.

CAUTION



HOT WHILE IN OPERATION. DO NOT TOUCH. KEEP CHILDREN, CLOTHING AND FURNITURE AWAY. CONTACT MAY CAUSE SKIN BURNS. SEE NAMEPLATE AND INSTRUCTIONS./ DEVIENT TRÈS CHAUD. NE TOUCHEZ PAS. ÉLOIGNEZ LES ENFANTS, LES VÊTEMENTS ET LES MEUBLES. UN CONTACT PEUT CAUSER DES BRÛLURES. VOIR LA PLAQUE SIGNALÉTIQUE ET LES INSTRUCTIONS.



MANUFACTURED BY/ FABRIQUE PAR : PACIFIC ENERGY FIREPLACE PRODUCTS LTD. 2975 ALLENBY RD., DUNCAN, BC V9L 6V8

U.S. ENVIRONMENTAL PROTECTION AGENCY CERTIFIED TO COMPLY WITH JULY, 1990, PARTICULATE EMISSION STANDARDS/ CERTIFIÉ CONFORME AUX NORMES SUR LES ÉMISSIONS DE PARTICULES (JUILLET 1990).

DATE OF MANUFACTURE/ DATE DE FABRICATION

J	F	M	A	M	J	J	A	S	O	N	D
2012	2013	2014	2015	2016	2017						

MADE IN CANADA/ FABRIQUÉ AU CANADA

270612

5050.7622

FP30-1





PACIFIC ENERGY FIREPLACE PRODUCTS LTD.

2975 Allenby Rd., Duncan, B.C. V9L 6V8

Phone: 250-748-1184

Web site: <http://www.pacificenergy.net>

Printed in Canada