

#0261

STOVEWORKS
1 BRANCH STREET
MEDFORD, NJ 08055
609-654-1384



Severn™

The Wood/Coal Heater for all Reasons

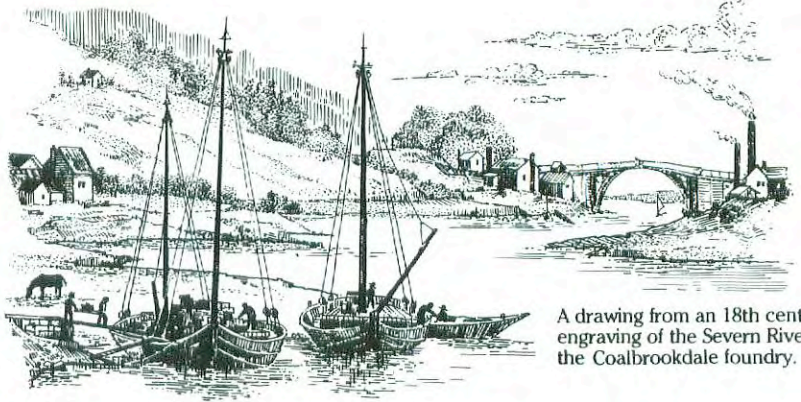

A drawing from an 18th century engraving of the Severn River near the Coalbrookdale foundry.

Named after the historic river that flows past the Coalbrookdale plant, the **Severn** uniquely combines four key features: **heating efficiency, good looks, wood/coal convertability and compact size.** Add its superb castings and workmanship and the Severn is the ideal all-around heater for the medium size American home.

Elegant, Timeless Styling

The classic proportions and fine detailing give the Severn the traditional look of a family heirloom. An extra feature is the removable front and side panels, available in decorator colors to match most any decor.

A Highly Efficient Heater

The Severn offers the advantage of both radiant and convection heating, providing up to 45,000 BTU's per hour. The primary air intake is easily controlled from the front and a built-in secondary air system maximizes burning efficiency.

Wood/Coal Interchangeability

The Severn also contains the advanced Coalbrookdale grate system that enables wood and coal to be burned interchangeably, without any messy grate change or expensive retro fit. A removable ash pan under the firebox makes emptying easy.

Ideal Compact Size

Only 17 inches deep (plus a removable ash lip) and 28 5/16" high, the Severn will fit comfortably on most living room hearths.

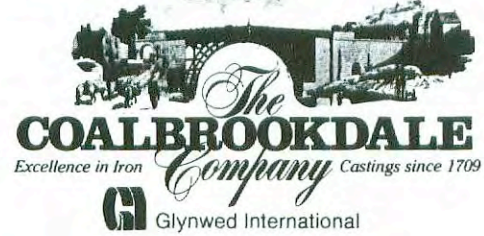

G Glynwed International



Warmth that looks as good as it feels.

The Severn is designed for those who want more than just a box that heats. With its classic good looks and changeable color panels, it is a handsome and decorative addition to any room.

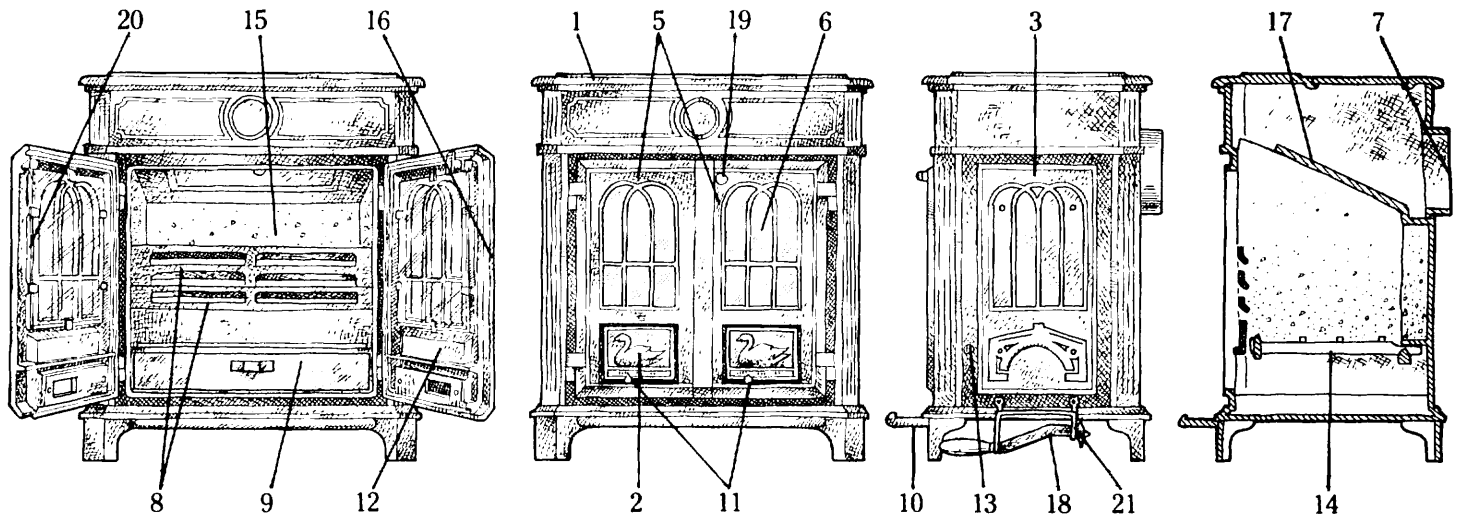

1. **TOP PLATE**
Flat top makes ideal cooking surface. Blanking plate allows for top flue exit if required.
2. **DECORATIVE FRONT PANELS**
feature a swan motif traditionally associated with the Severn River. Available in black or optional enameled colors.
3. **CONVECTION SIDE PANELS**
portray the graceful arches of the world's first iron bridge, which still spans the Severn River. Functionally they provide convected heat and reduce side clearances.
4. **ALL CAST IRON**
for a long lifetime of performance.
5. **TWO FRONT LOADING DOORS**
for easy refueling.
6. **GLASS PANELS**
allow the charm of the fire to fill a whole room during the airtight mode of operation.
7. **REAR FLUE EXIT**
for free standing installation, as well as installation into almost any existing fireplace.
8. **TWO PIECE FRONT BAR**
allows for easy loading of wood or coal while preventing fuel or cinders from spilling out of the firebox.
9. **ASH PAN**
easily lifts out for quick disposal of wood and coal ash.
10. **DETACHABLE ASH LIP**
prevents ash or coals from falling on hearth.
11. **PRIMARY DRAFT CONTROLS**
are manually operated to control the intensity of the fire. Settings are numbered 0 through III for ease of operation.
12. **SECONDARY DRAFT CONTROLS**
are hidden by the front panels. Factory set to provide optimum secondary combustion. They also keep the glass panels free of soot and tars by moving pre-heated air along the surface of the glass.
13. **SHAKER GRATE AXLE HUB**
makes it safe and easy to periodically shake down the ashes with the tool provided.
14. **SHAKER GRATE SYSTEM**
is so advanced it requires no internal set-up changes or expensive retro-fit kits to switch from wood to coal burning. In fact, you can switch from burning one fuel to the other instantaneously!
15. **FIRE BRICK LINER**
ensures maximum stove life and performance.
16. **DOOR GASKETS**
provide an airtight seal.
17. **BAFFLE PLATE**
directs the air flow for the most efficient fuel combustion. Removal of center section allows easy access for cleaning stovepipe.
18. **UNIVERSAL TOOL**
shakes down the ashes, opens the loading doors and is used to lift out the ash pan.
19. **DOOR BUTTON**
is easily turned to open and close the doors of the Severn.
20. **WINDOW GASKETS**
hold the glass panels snugly in the doors of the Severn and maintains an airtight seal.
21. **WIRE CRADLE**
for holding draft control tool.
22. **OPTIONAL HEAT SHIELD**
(not shown) reduces back clearance.

SPECIFICATIONS

Heat Output:	45,000 BTU'S/Hour
Length of Fire:	Up to 20 Hours Coal, Up to 12 Hours Wood
Area Heated:	10,000 Cubic feet
Fuel:	Coal and Wood
Log Length:	18"
Flue Size:	6"
Flue Exit:	Top or Rear
Weight:	500 lbs.
Height:	28 ⁵ / ₁₆ "
Width:	26 ³ / ₄ " Top, 26" Btm.
Depth:	17" Top, 16 ³ / ₄ " Btm. (does not include 4" detachable ash lip)
Rear Flue Height	24" (top)
Weight of Load:	60 lbs. Coal 40 lbs. Wood
Min. Clearances to Walls:	Side 18", Back 28". Back with optional heat shield 18". Contact local building or fire officials.

The Coalbrookdale Company

522 Parkway View Dr., Pittsburgh, PA 15205.
Sales Office: RFD 1, Box 477, Stowe, VT 05672.
802-253-9727

Severn™
A British Classic