



Fireback Kit #5927

Installation Instructions

for use on

Encore Model 2550

Please read these instructions before beginning the repair procedure.

General Information

The Model 5927 Encore Fireback Kit is for use with Model 2550 Encore stoves. These stoves allow access to the catalytic combustor through the firebox by removing a hood and the lower fireback. As you face the left end of the stove, the damper handle mounts closer to the rear of the stove than to the front. If there is a question about the model number of the stove, check the steel label fastened to the stove back.

Material provided:

- (1) Upper fireback and damper assembly
- (1) Lower fireback
- (1) Combustion throat hood
- (1) Secondary probe assembly
- (1) Refractory (insulating) assembly
- (2) 1/4"-20 x 1 1/2" hex head bolts
- (1) Tube of gasket cement
- (1) 5/16" x 36" fiberglass gasket

Tools required:

- | | |
|--------------------------|-----------------------------|
| Phillips screwdriver | Standard (flat) screwdriver |
| 7/16" hex ratchet wrench | 5/32" Allen wrench |
| Hammer | 3/16" drill bit |
| Dust mask | Goggles |
| Knife | Putty knife |
- You may also need a file or grinder

Before starting the repair procedure, be sure the stove is cold. Note that ashes and embers can stay hot for a long time; remove them and store them properly in a sealed metal container on a noncombustible surface away from all nearby combustibles. The empty ashpan will be a handy storage spot for hardware, tools and small parts.

Work in a clean, well-lighted area. Protect your work area with tarps or drop cloths. Protect yourself with goggles and dust mask.

In these instructions, 'right' and 'left' are given as you face the stove.

You may need to file or grind some edges on the new cast iron parts to enable them to fit properly.

Dis-Assembly

1. Remove the griddle and the front doors. Lift each door until the bottom hinge pin clears the bottom hinge hole; then swing the bottom of the door away from the stove, and lower it so the top hinge pin clears the top hinge hole. Set the doors face down on a padded surface.
2. Unbolt the andirons from the lower front panel of the stove, and set them aside. Lift out the grate and set it aside.
3. Lift the lower edge of the throat hood (Fig. 6, Item 10) toward the front and slide the hood to the left or right. If you slide it to the right, the support pin will then drop off the left bracket on the upper fireback; then slide it back toward the left to disengage the hood from the upper fireback.

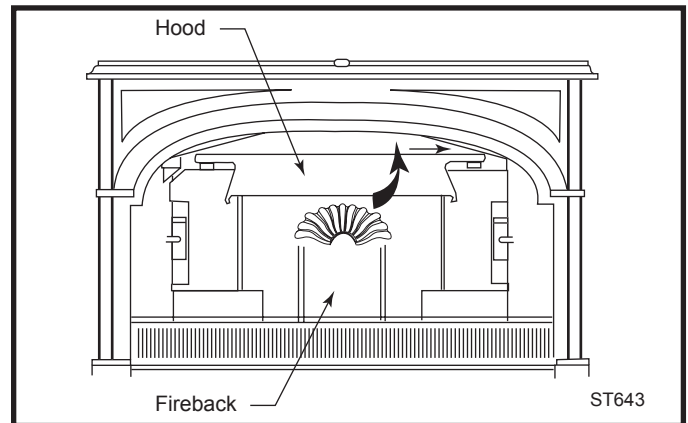

Fig. 1 Remove the throat hood.

4. Use a hammer to tap the two wedges (Fig. 6, Item 11) upward from their brackets, and remove the wedges.

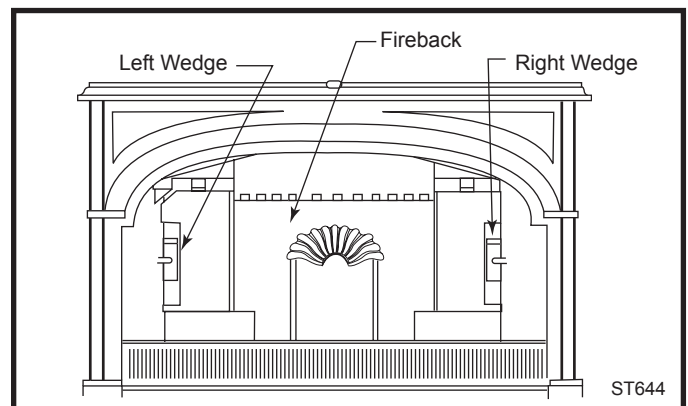

Fig. 2 Tap the wedges out with a hammer.

5. Remove the lower fireback (Fig. 6, Item 12) by pulling the upper edge toward the front. Then lift it and angle it out of the stove through the front door or through the griddle opening. Scoop out any ashes or charcoal in the bottom groove where the lower edge of the lower fireback fits.

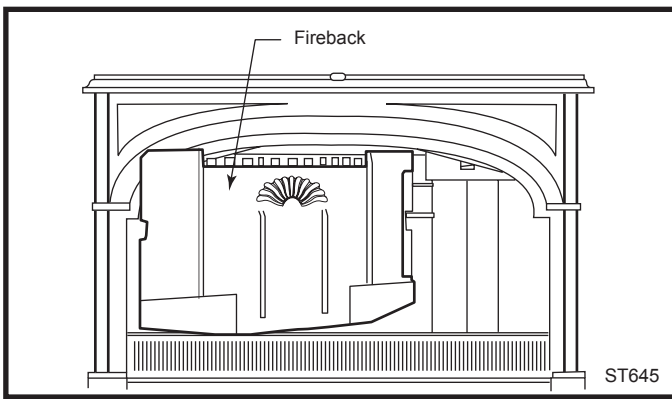

Fig. 3 Lift out the lower fireback.

6. Remove the left and right inner walls (Fig. 6, Items 5, 13) of the stove. Hex bolts at the top and bottom hold them in place. These walls have rope gaskets, forming seals between the inner walls and the outer walls of the stove. With the bolts removed, pry the forward edges of the inner walls toward the center of the firebox; it will also help to slide the bottom edges of the inner walls toward the center of the firebox. The panels will come out through the front opening or through the griddle opening.

7. Use the Allen wrench to loosen the Allen bolt (Fig. 6, Item 14) in the base of the damper handle (Item 15). Leave the loosened bolt in the handle to keep from misplacing it. Pull the handle base off the damper rod. (Fig. 6, Item 7)

8. If the stove has a steel rear outer heat shield, remove it. Four bolts hold it to spacers threaded into the back of the stove. Leave the spacers in place.

9. A hex bolt (Fig. 6, Item 1) on each side of the stove back holds the upper fireback assembly (Item 6) in place. Remove and discard these bolts. Keep the washers. From inside the firebox, pull the right-hand end of the upper fireback forward; you may need to use a flat screwdriver to pry the fireback loose from the panel behind it. With the upper fireback assembly removed from the stove, save the #22 spacer and the #23 washer (Fig. 6) for reuse.

10. Remove the catalyst access panel (Item 16), part of the refractory package (Item 3) that houses the catalytic combustor (Item 17). It is friction-fit into place. Wiggle it slightly to loosen it. Notice its positioning; this will be important when you install the catalyst in the new refractory package.

11. Remove the catalytic burner carefully, inspect and clean it, and set aside. To clean it, take outdoors and blow gently through it. Do not use compressed air; do not run anything through the honeycomb. The catalyst is a thin coat of platinum on the ceramic honeycomb, and friction can remove the coating, shortening the unit's life. Check your Encore owner's manual for details on evaluating the catalyst.

12. Remove the refractory package. (Fig. 6, Item 3) Pull it straight toward yourself, and slide it out through the front door opening. Put it in a closed bag to contain any airborne dust.

13. On the outer back side of the stove, there is a steel plate (Fig. 6, Item 21) held in place with two Phillips bolts. Remove the bolts and the steel plate.

14. Behind the steel plate, there is a secondary probe assembly (Item 20). This consists of a probe and a bi-metal coil secured by a Phillips screw. (Fig. 5) There is a slender steel rod between the end of the coil and a pivoting valve plate (Item 19). Remove the Phillips screw and pull the coil and probe partway out of the stove back. When the probe is halfway out of the stove back (about 1" showing), remove the slender rod from the tab at the end of the coil. Leave the rod hanging from its tab on the secondary valve. Leave the secondary valve, Item 19, in place.

15. Remove the two steel heat deflectors (Items 4, 18) from the back of the firebox; these were originally on each side of the refractory package.

Re-Assembly

Use a hammer and a cold chisel or old screwdriver to remove any remaining cement from the upper rear area of the firebox, where the upper fireback attaches. Remove any debris from the stove's back chamber.

1. Remove the catalyst access panel (Fig. 6, Item 16) from the new refractory chamber. Install the chamber in the back of the stove, with the opening facing forward.

2. Reinstall the two steel heat deflectors, (Fig. 6, Items 4, 18) one on each side of the refractory package. The shorter arm of each goes at the bottom of the deflector, with the longer arm against the cast iron back sides of the rear chamber. These deflectors provide important protection from the very hot gases leaving the refractory chamber.

3. Slide the catalytic combustor (Fig. 6, Item 17) into place within the refractory chamber. Notice that the openings of the honeycomb must be on the top and bottom horizontal surfaces of the combustor, as shown in Figure 6.

4. Install the refractory access panel in front of the catalyst. It friction-fits into place.

5. Install the new upper fireback assembly. Place the #22 spacer and the #23 washer on the protruding end of the damper rod. (Fig. 6) Swing the assembly's left end into the firebox, with the end of the damper rod passing through the hole in the left outer stove side. Swing the right end into position, and secure the assembly with two new 1/4"-20 x 1 1/2" bolts. Be sure to use the original washers. These bolts should be snug but not tight, especially if the stove back is enamelled. Overtightening these bolts can cause excess tension on them and/or the upper fireback assembly.

6. Attach the damper handle (Fig. 6, Item 15) to the damper rod (Item 7), and secure it with the Allen bolt. Test the action of the handle to ensure the damper works smoothly. The damper should 'lock' closed when the handle is aimed fully forward. Adjust as needed, following the directions in the Encore Owner's Guide.

7. Reinstall the left and right inner walls of the firebox (Fig. 6, Items 5, 13), securing each with the two 1/4"-20 x 1 1/2" bolts and washers originally removed. These panels have rope gasketing on the (hidden) back sides; generally this does not need to be replaced. Use cement to keep it in place if it has loosened from its channels.

8. Retest the action of the damper handle, and make any adjustments necessary.

9. Check the tube of gasket cement. This is a clay-based, water-solvent material, and the water can separate from the clay during storage. Before you open the tube, knead it in your hands to ensure the cement and the water are thoroughly mixed. Cut off the tip of the tube. Apply a thin bead of gasket cement to the back of the new lower fireback, in the channel shown in Figure 4. Twist the ends of the fiberglass gasket, to keep it from unraveling. Press the gasket into the channel. Do not cut the gasket to final length until you have positioned it in the cemented channel.

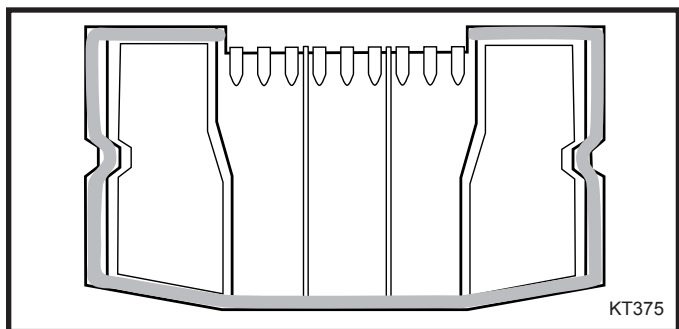

Fig. 4 Fiberglass gasket on back of lower fireback.

10. Clear the lower fireback's channel in the bottom of the firebox of ashes and charcoal. Install the lower fireback (with the seashell design forward). Be sure it sets fully down into the channel. Secure the fireback with the two cast iron wedges. Tap these wedges in until they are snug, but not tight.

11. Install the new combustion throat hood (Fig. 5, item 10). Slide a protruding pin on one end fully onto the corresponding support bracket on the upper fireback, then slide the pin in on the trailing end of the hood onto the other support bracket. Center the hood left-to-right on the fireback, and let its lower edge hang against the lower fireback.

12. On the back of the stove, gently hand-turn a 3/16" drill bit through the hole where the original secondary probe was, and into the new refractory chamber. Turn the bit till it does not meet resistance.

13. Attach the slender steel rod to the tab at the end of the bimetal coil, part of the new secondary probe assembly. Carefully press the secondary probe into place through the hole you made in the refractory chamber. Do not jam the probe into place, as this can break pieces off the refractory chamber. Secure the probe with the Phillips pan-head bolt you removed in disassembly step 14. The correct positioning for the probe is shown in Figure 5. Note the tab on the end of the coil is in the 4 o'clock to 5 o'clock position, when the stove is cold.

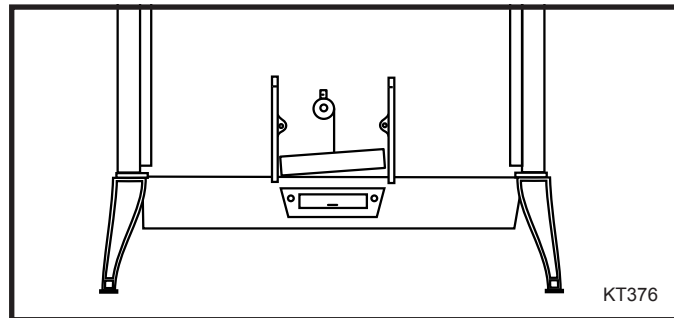

Fig. 5 Rear view of stove.

14. Join the bimetal coil to the secondary air valve. The U-curved end of the slim steel rod joins to the coil, and the L-shaped end of the rod goes through the small bracket on the pivoting valve plate.

15. Replace the steel cover over the secondary air valve assembly with two Phillips bolts.

16. If the stove has a steel rear heat shield, replace it by attaching it to its four spacers.

17. Replace the slotted grate (Fig. 6, Item 9); the wider openings face downward, toward the ashpan.

18. Replace the andirons and the griddle.

19. Replace the doors. Handle them carefully, especially if they are enamelled. Slide the top hinge pins into the upper holes in the stove front, then swing the bottom edge of the door toward the stove and slide the bottom hinge pins into their holes. Make sure the doors settle fully into their correct position. Check the latching of the doors; do not let the right door swing loosely toward the stove, as the protruding latch may chip the enamel on the stove front.

20. Dispose of the original cast parts, and the original refractory chamber, by sending them to a landfill. The refractory is ceramic fiber, and will not burn. Wear a dust mask whenever you handle the chamber, it will be easier to handle if you put it in a closed plastic bag.

21. When you refire the stove, you must 'cure' the new cast iron panels, as you did when the stove was new. Build a series of small fires, with each one 100°F hotter and an hour longer than the previous one, until you have reached a normal operating temperature of 600°F. Then you can resume normal firing.

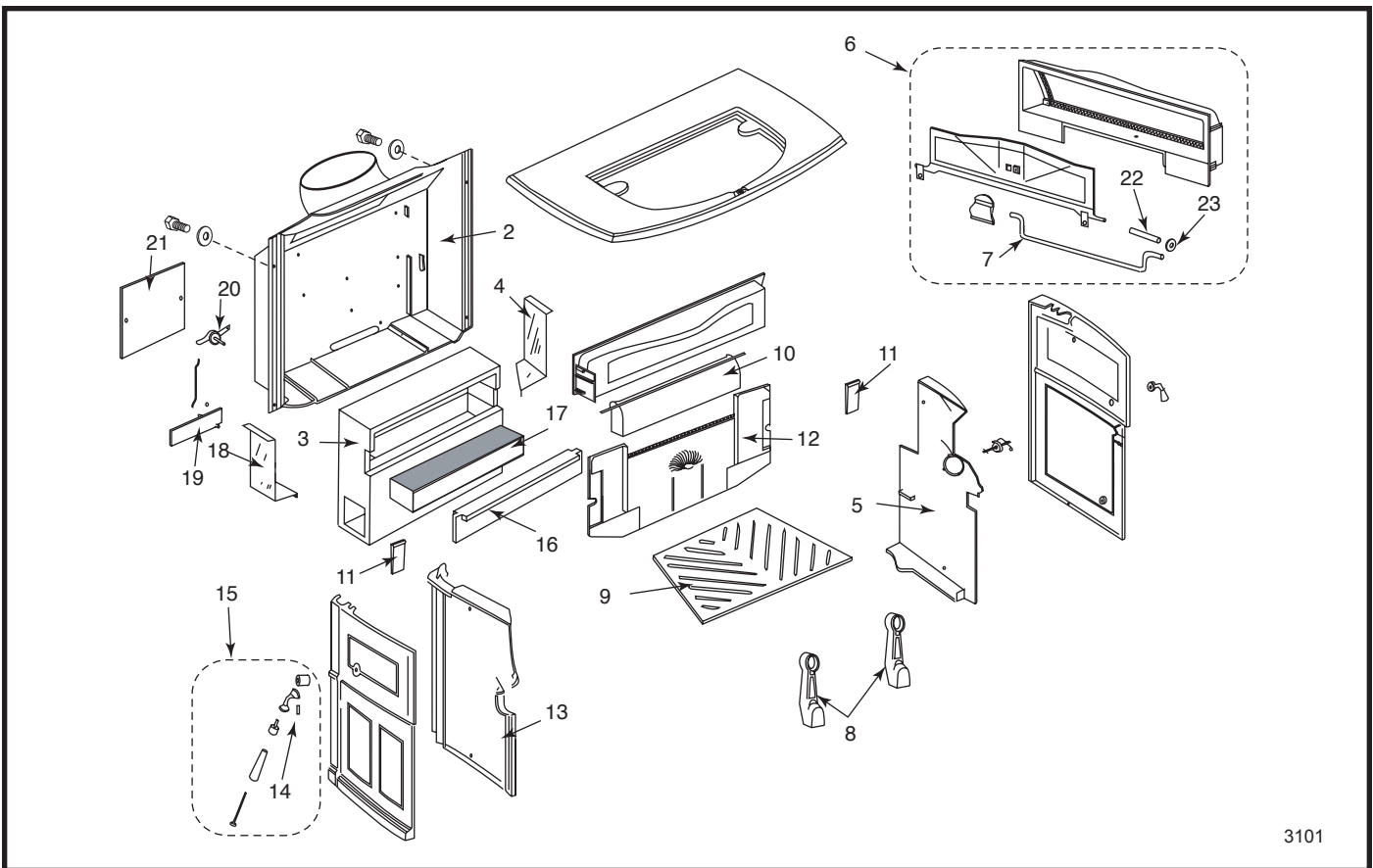

3101

Fig. 6 Firebox parts diagram, Defiant Encore Model 2550 stove.

- | | |
|-----------------------------|---|
| 1. Upper fireback bolts | 13. Left inner side |
| 2. Outer back | 14. Damper handle Allen bolt |
| 3. Refractory chamber* | 15. Damper handle |
| 4. Right heat deflector | 16. Catalyst access panel (refractory)* |
| 5. Right inner side | 17. Catalyst |
| 6. Upper fireback assembly* | 18. Left heat deflector |
| 7. Damper torsion bar* | 19. Secondary thermostat valve |
| 8. Andiron (2) | 20. Secondary probe thermostat |
| 9. Grate | 21. Secondary thermostat cover |
| 10. Fireback throat hood* | 22. Spacer** |
| 11. Wedge (2) | 23. Washer** |
| 12. Lower fireback* | |

* Included in the #5927 kit.

** Not included in the #5927 kit.

CFM Corporation reserves the right to make changes in design, materials, specifications, prices and discontinue colors and products at any time, without notice.

CFM Corporation

2695 Meadowvale Blvd. • Mississauga, Ontario, Canada L5N 8A3
800-668-5323 • www.cfmcorp.com