

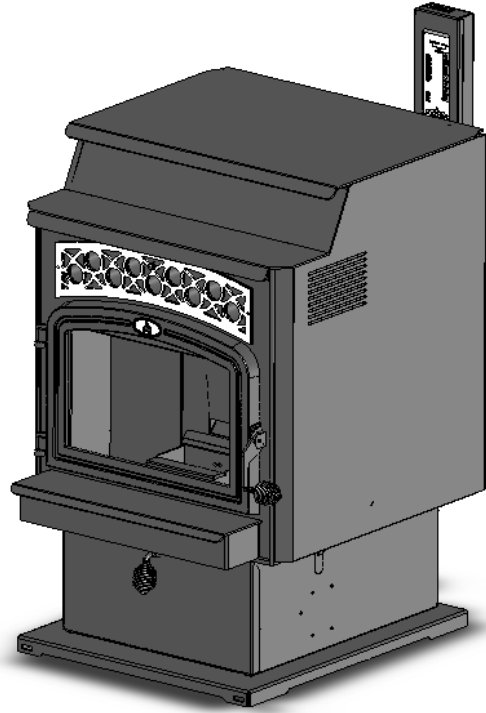

OLIVIA

Corn / Pellet Stove

Model: #OLV-PC



OPERATING & MAINTENANCE MANUAL

Contact local building or fire officials about restrictions and installation inspection requirements in your area.

SAVE THESE INSTRUCTIONS

Please read this entire manual before installation and use of the corn/pellet fuel burning room heater.

Failure to follow these instructions could result in property damage, bodily injury or even death.

TABLE OF CONTENTS

Features.....3

Safety Information.....4-5

Installation.....4

Precautions.....4

Safety Devices.....5

Circuit Control Board.....6

Operating Instructions.....7-9

Fuel Quality / Storage.....7

Pre-lighting Checklist.....7

Thermostat Control.....7

Burning with corn.....8

Burning with wood pellets.....8

Burning with corn / pellet mix.....9

Heat Setting / Damper Setting Chart.....9

Subsequent Burn Procedures.....10

Diagnostic Features.....10

Shutting OFF the Stove.....10

Maintenance Instructions.....11-14

Daily Maintenance.....11

Weekly Maintenance.....11-12

2-Month Maintenance.....12-14

Annual Maintenance.....14

Troubleshooting.....15

Control Board Diagnostics Troubleshooting.....16

Replacement Parts.....17-18

Description.....17

Illustration.....18

Complete warranty information and return to: Kozy Heat Fireplaces
Attention: Warranty Registration
P.O. Box 577
Lakefield, MN. 56150

OLIVIA

CORN / PELLET STOVE

FEATURES

Figure shown with optional decorative grill.

Tested for use with corn, pellets or an unlimited mixture.

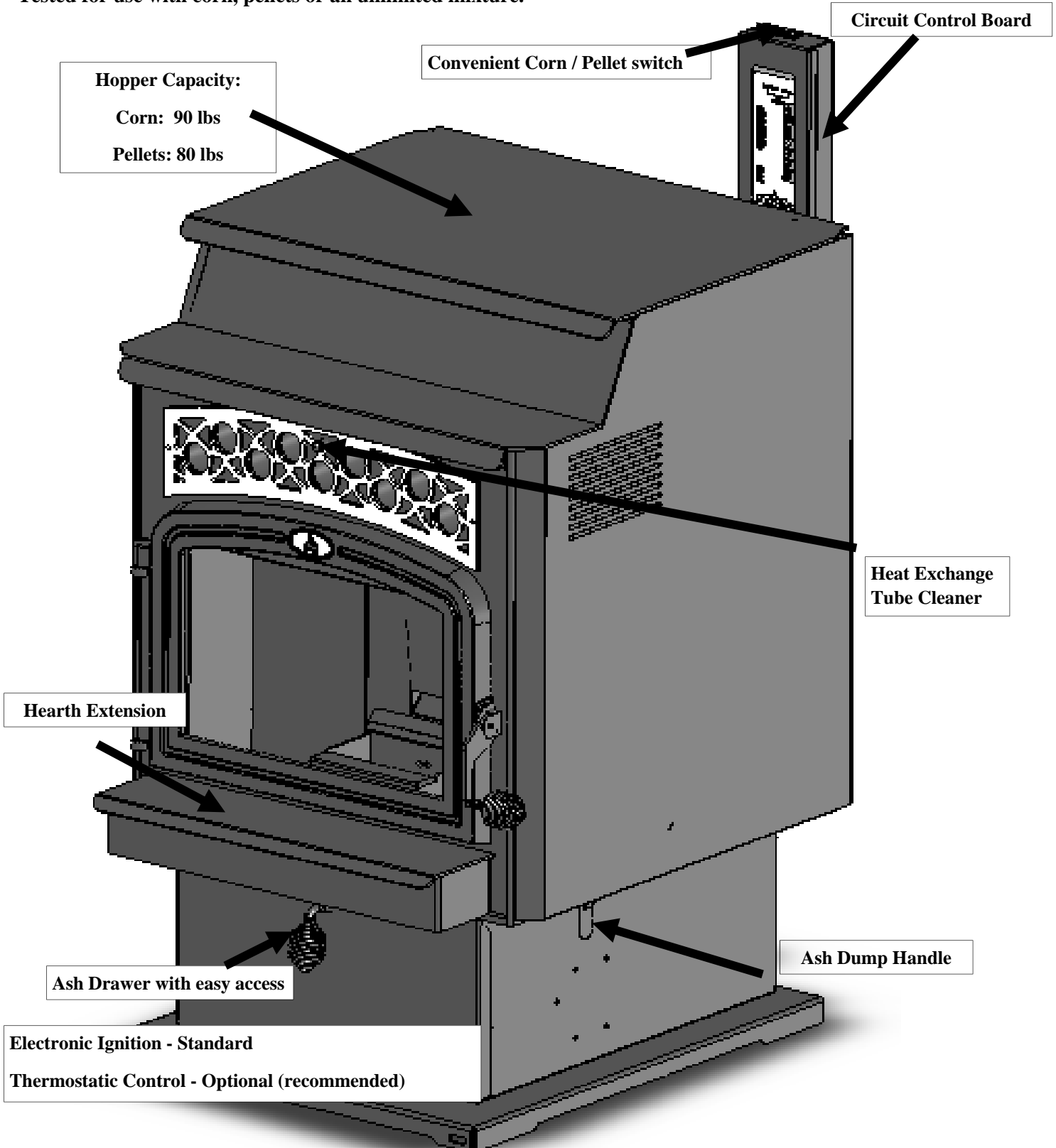

SAFETY INFORMATION

INSTALLATION: This stove must be installed by a qualified installer in accordance with the installation manual provided. Improper installation and /or maintenance may create a fire hazard, resulting in an unsafe condition, poor performance, and may void your warranty.

1. Please read this entire manual before operating this stove. Make sure the installer of this product reviews the operating procedures, all maintenance requirements, and answers any questions you may have.
2. This stove is approved for use with shelled corn or wood pellets only. An unlimited mixture of shelled corn / wood pellets may also be used.
3. Please be aware that it is normal for the stove to give off odors during the initial burn period. This is short-term and the result of paint curing and other agents used in the manufacturing process.
4. This stove will be **HOT WHILE IN OPERATION**. Keep children, clothing, and furniture away from all stove surfaces. Direct contact with stove surfaces while in operation may cause severe burns.
5. This stove has safety interlock switches built into the circuit control board which will not allow continuous burning in the event of a problem. Keep the door, ash drawer and hopper lid closed whenever this stove is in operation. All exhaust connections must be tightly sealed to prevent the possibility of carbon monoxide from entering the home.
6. The combustion air intake pipe should be connected to an outside fresh air source. This will prevent 'smoke back' into the house in circumstances such as a power outage.

CAUTION: Operate this stove only with the fuel hopper lid closed. Failure to do so may result in emission of combustion products from the hopper under certain conditions. This stove is equipped with a safety interlock device which will turn off auger operation when the hopper lid is opened. To prevent the fire in the burn pot from extinguishing, do not allow hopper lid to remain open longer than 30-45 seconds. If hopper lid is left open, the control board will continue to operate as normal, but the auger will not cycle until the stove has been shut off and restarted.

SAFETY PRECAUTIONS

DISPOSAL OF ASHES: Ashes should be placed in a metal container with a tight fitting lid. The closed container of ashes should be placed on a noncombustible floor or on the ground, well away from all combustible materials, pending final disposal. If the ashes are disposed of by burial in soil or otherwise locally dispersed, they should be retained in the container until all cinders have thoroughly cooled.

NEVER USE GASOLINE, gasoline-type lantern fluid, kerosene, charcoal lighter fluid or similar liquids to start or 'freshen up' a fire in the stove. Keep all such liquids well away from stove while in use.

SOOT AND FLY ASH: *Formation and Need for Removal.* The products of combustion will contain small particles of flyash. The flyash will collect in the exhaust venting system and restrict the flow of the flue gases. Incomplete combustion, such as occurs during startup, shutdown, or incorrect operation of the room heater will lead to some soot formation which will collect in the exhaust system. The exhaust venting system should be inspected at least once a year to determine if cleaning is necessary.

DO NOT USE ANOTHER MANUFACTURER'S BURN POTS, GRATES, OR ANY OTHER COMPONENT WHICH HAVE NOT BEEN TESTED OR APPROVED FOR USE WITH THIS STOVE.

DO NOT OVER FIRE THIS STOVE. (OVERFILL BURN POT AT STARTUP). Follow all instructions regarding the proper use of this stove.

CAUTION: The electrical components of this stove are not owner serviceable. Contact your dealer for proper diagnosis of any electrical problems that may occur and to provide service.

SAFETY DEVICES

High Limit Switch - The high limit switch is an 'overheat' safety switch which shuts off fuel feed if the stove exceeds temperatures above the normal operating temperature. This switch is a manual reset type.

Proof of Fire Switch - (P.O.F). Responds to temperature rise in the exhaust system. The stove will stop operating if temperatures above 110°F are not met during startup or drops below 90° F during normal operation.

Vacuum Switch - When stove is 'ON', the exhaust fan creates vacuum inside the firebox. The control board continuously monitors for vacuum during operation. If vacuum pressure is lost for longer than 30 seconds, the stove will shut down.

Interlock Safety Switch - Located on the top flange of hopper. If hopper lid is opened, the interlock safety switch deactivates the auger. This switch has been installed for your safety and should never be disconnected for any reason.

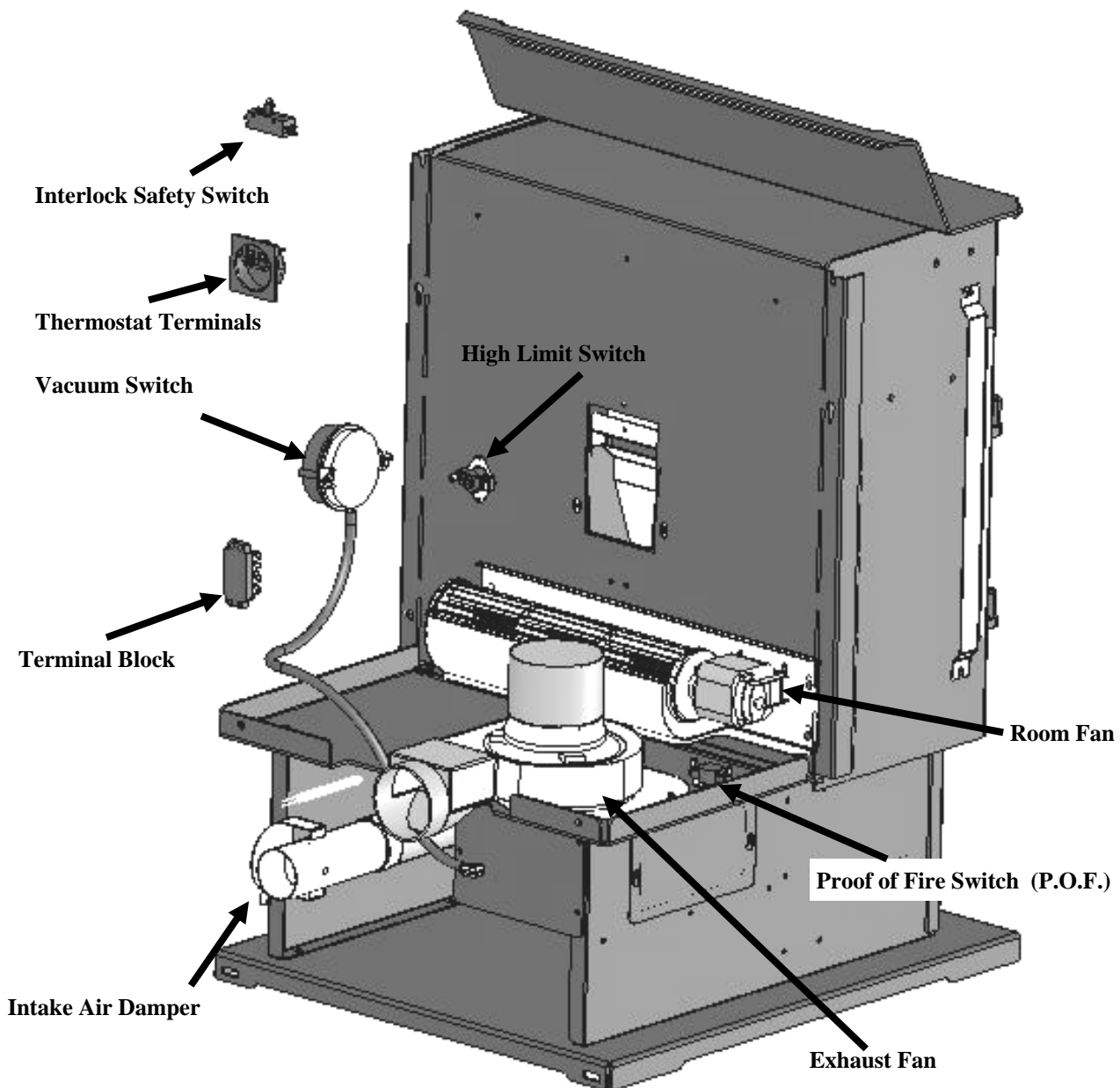

View: Back of stove with hopper removed.

CIRCUIT CONTROL BOARD

FUNCTIONS

A. ON/OFF:

Turns the circuit control board 'ON' and 'OFF'. It is also used to 'reset' the board after switching to Diagnostic mode. The ON/OFF LED light will blink for the first 10 minutes. When successful start-up is achieved, the light will remain steady.

NOTE: If a thermostat is installed, the ON/OFF LED light will blink continuously until the thermostat calls for heat, at which time the light will remain steady. When the set temperature is reached, the light will resume blinking.

B. AUGER:

Corn Setting:

The auger will run 3 times within the first 30 seconds after the control circuit board has been turned 'ON'. The #1 heat level LED light will turn on. The auger will start operating 8 ½ minutes after the control circuit board has been turned 'ON'. The AUGER button allows you to manually auger fuel into burn pot on startup, if needed. When sufficient heat has been applied to the Proof of Fire switch (P.O.F.), the room fan will turn 'ON'.

IMPORTANT: If the auger button is pressed and held for 2 minutes or more during normal operation, the control circuit board will 'shutdown'. This is an over fire safety precaution.

NOTE: If stove was turned 'OFF' and not unplugged, it will revert back to previous setting at next startup.

Pellet Setting:

The auger will run 3 times within the first 30 seconds after control circuit board has been turned 'ON'. The #1 heat level LED light will turn on and auger will cycle for 4 minutes. During this period the pellets will ignite automatically. After 8 ½ minutes the auger will resume cycling. The AUGER button allows you to manually auger fuel into burn pot on start up if needed. When sufficient heat has been applied to the Proof of Fire switch (P.O.F.), the room fan will turn 'ON'.

IMPORTANT: If the auger button is pressed and held for 2 minutes or more during normal operation, the control circuit board will 'shutdown'. This is an over fire safety precaution.

NOTE: If stove was turned 'OFF' and not unplugged, it will revert back to previous setting.

C. FAN:

Adjusts the room fan on heat setting levels 1 & 2 only. The fan initially starts on HIGH. Press the fan button once to set to LOW. Pressing the fan button again returns fan to HIGH. On heat levels #3-#5 the fan runs on HIGH only.

D. HEAT LEVEL:

Advances heat settings between level #1 and level #5. If level #5 is selected, depressing button again will return heat setting to level #1. The 'LED' light indicates the active heat setting.

E. AUGER TRIM:

Adjusts fuel feed rate in the #1 heat setting only.

Auger trim level 1: - (#1 LED light is on).

Auger trim level 1 High: - Press auger trim button once. (#1 & #4 LED lights are on).

Auger trim level 1 Low: - Press auger trim button a second time. (#1 & #3 LED lights are on).

Pressing auger trim button a third time will return setting to level 1.

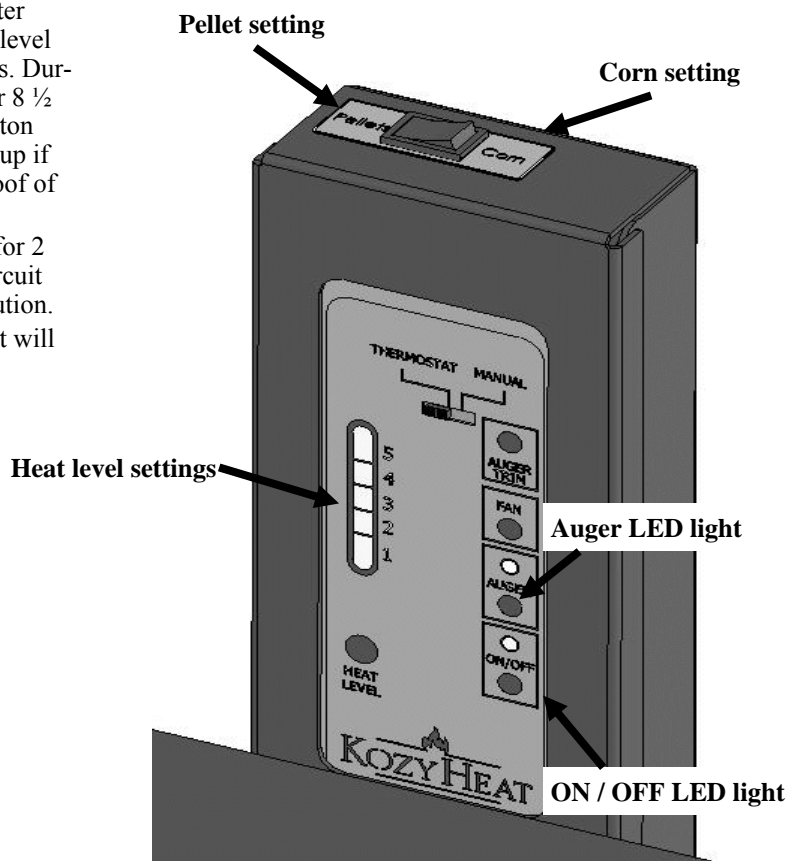

OPERATING INSTRUCTIONS & MAINTENANCE GUIDELINES

FOR USE WITH CORN OR WOOD PELLETS ONLY - OR AND UNLIMITED MIX OF BOTH

Contact your dealer for information on where to purchase high quality fuel products.

SHELLED CORN

Corn must be 15% or less moisture content. Corn must be dry, clean, and of good quality. Wet and /or poor quality corn will result in poor burn performance.

NOTE: Screen corn with excessive grain dust. Remove large pieces of cob and corn stocks.

STORAGE: Shelled corn should be stored where it will not absorb moisture. Do not store corn within the clearance requirements or in an area that would hinder routine cleaning & maintenance. Keep corn tightly covered to prevent rodents.

WOOD PELLETS

STORAGE: To prevent moisture absorption, wood pellets should be left in their original sealed bag until using. Pellets with excessive moisture may plug auger and possibly cause damage.

INITIAL PRELIGHTING CHECKLIST

- Hopper filled with fuel: corn, pellets, or a mixture of both.
- Hopper lid closed.
- Ash dump, located in bottom of burn pot, in 'closed' position.
- Burn pot properly seated.
- Control circuit board pivoted clockwise to 'exposed' position.
- Intake air damper set to 1/4 open position.
- If thermostat (recommended) is installed, circuit control board set to 'MANUAL' for first 10 minutes before switching to 'THERMOSTAT' setting.
- If thermostat is not installed, set the circuit control board to 'MANUAL' at all times.

WALL / REMOTE THERMOSTAT CONTROL (recommended)

This stove is capable of operating on a wall thermostat or a thermostat with remote. A feature has been built into the circuit control board which delays time between each heat setting to allow the stove to react at each subsequent level. It will take the stove approximately 2-5 minutes for the control board to operate at the full capacity for the heat level it has been set to. As the room temperature falls below the thermostat temperature setting, the stove will operate at one of the (5) settings previously chosen. When the room temperature reaches the thermostat set temperature, the stove will automatically operate at the lowest setting (#1). NOTE: The LED will remain lit at chosen setting. Installing a thermostat will reduce fuel consumption and improve comfort and efficiency.

LIGHTING YOUR STOVE

SHELLED CORN

1. Set control switch, located on top of circuit board, to 'CORN' setting.
2. Place 1 cup or approx. 8 oz. of wood pellets in burn pot. (Always use wood pellets to light stove.)
3. Close and latch door.
4. Set intake air damper to 1/8 open position.
5. Press ON/OFF button on circuit board once. The LED light above the button will illuminate, turning on the electronic igniter in burn pot, beginning the start up program.
The pellets will begin to smoke and combust into flame in approximately 3-4 minutes. In approximately 6 minutes the P.O.F. will close, turning the room fan 'ON'. After 8 minutes, the auger will cycle 'ON' and begin feeding corn to the burn pot. The LED light just above 'Auger' button will light up each time the auger cycles.
NOTE: The electronic igniter will stay on for approximately 7 minutes, even though flames may be visible in burn pot.
6. If the room fan does not turn 'ON' 6-8 minutes after control circuit board has been turned 'ON', press the ON/OFF button to turn stove 'OFF'. Press again and hold for 2 seconds to turn stove back 'ON'.
7. Adjust heat setting level to desired position - #1 - #5, with #5 being the highest. It is recommended to leave the setting at level #1 until fire is well established in the burn pot.
8. If wall thermostat or remote thermostat have been installed, switch circuit control board to 'THERMOSTAT' setting after stove has burned for 10 minutes.

NOTE: The ON/OFF LED light will blink continuously until the thermostat calls for heat, at which time the light will remain steady. When the set temperature is reached, the light will resume blinking.

WOOD PELLETS

1. Set control switch, located on top of the circuit board, to 'PELLET' setting.
2. Set intake air damper to 1/4 open position.
3. Place 1 cup or approx. 8 oz. of wood pellets in burn pot. Close and latch the door.
4. Press ON/OFF button on circuit board once. The LED light above the button will illuminate, turning on the electronic igniter in burn pot, beginning the start up program. The auger will begin dropping pellets into burn pot 30 seconds after control circuit board has been turned 'ON'. The auger will cycle for 5 minutes, stop completely for 3 minutes, allowing pellets to automatically ignite.
5. Pellets will smoke and combust into flame in approximately 4 minutes. In approximately 6 minutes the P.O.F. will close, turning the room fan 'ON'. After 8 minutes, the auger will cycle 'ON' and begin feeding pellets to burn pot. The LED light just above the 'Auger' button will light each time the auger cycles.
NOTE: The electronic igniter will stay on for approximately 7 minutes, even though flames may be visible in burn pot.
6. If the room fan does not turn 'ON' approx. 6 minutes after the control circuit board has been turned 'ON', press ON/OFF button to turn 'OFF' stove. Press again and hold for 2 seconds to restart.
7. Adjust heat setting level to desired position - #1 - #5, with #5 being the highest.
8. If a wall thermostat or remote thermostat have been installed, switch circuit control board to 'THERMOSTAT' setting.

NOTE: The ON/OFF LED light will blink continuously until the thermostat calls for heat, at which time the light will remain steady. When the set temperature is reached, the light will resume blinking.

9. After burning 10 minutes, adjust intake air damper to proper setting. See chart on page 9.

50/50 OR UNLIMITED MIXTURE OF CORN / PELLETS

1. Set control switch, located on top of circuit board to one of the following:

‘CORN’ When mixture is more than 50% corn.

NOTE: At start-up, ‘PELLET’ setting may be used for a brief period of time. Extended use on ‘PELLET’ setting will cause the burn pot to ‘flood’.

‘PELLET’ setting: When mixture is 50% or more pellets.

2. Place 1 cup or approx. 8oz. of wood pellets in burn pot.(Always use wood pellets to initially start stove). Close and latch door.

3. Set intake air damper to 3/16 open position.

4. Press the ON/OFF button on circuit board once. This will illuminate the LED light just above the button, turning on the electronic ignition probe in the burn pot, beginning the start up program.

The pellets smoke and combust into flame in approximately 4 minutes. In approximately 6 minutes the P.O.F. will close, turning the room fan ‘ON’. After 8 minutes, the auger will turn ‘ON’ and begin feeding corn/wood pellets mixture to the burn pot. The LED light above ‘Auger’ button will light each time the auger cycles. If auger is empty, it will take several minutes for fuel to drop. Use auger button to feed fuel if needed.

NOTE: The electronic igniter will stay on for approximately 7 minutes, even though flames may be visible in burn pot.

5. If the fan does not turn ‘ON’ in 6-8 minutes after the control circuit board has been turned ‘ON’, press ON/OFF button to turn ‘OFF’ stove. Press again and hold for 2 seconds to restart.

6. Adjust heat setting level to desired position - #1 - #5, with #5 being the highest.

7. If a wall thermostat or remote thermostat have been installed, switch circuit control board to ‘THERMOSTAT’ setting.

NOTE: The ON/OFF LED light will blink continuously until the thermostat calls for heat, at which time the light will remain steady. When the set temperature is reached, the light will resume blinking.

8. After burning for 10 minutes, adjust intake air damper to proper setting. See chart below.

Various fuel products, as well as chimney configurations will determine the correct intake air damper setting. The chart above is approximate. You may find that the optimum setting for your stove may vary from what is listed.

HEAT SETTING / INTAKE DAMPER SETTINGS					
CORN		PELLETS		MIX	
HEAT SETTING	DAMPER SETTING	HEAT SETTING	DAMPER SETTING	HEAT SETTING	DAMPER SETTING
1	1/8	1	1/4 OPEN	1	3/16 OPEN
2	1/4	2	1/2 OPEN	2	3/8 OPEN
3	1/4	3	1/2 OPEN	3	3/8 OPEN
4	1/4	4	FULL OPEN	4	3/4 OPEN
5	1/4	5	FULL OPEN	5	FULL OPEN

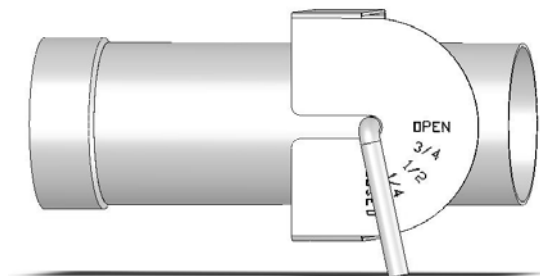

PRIOR TO EACH BURN

1. Check ash drawer capacity. (Located under the hearth extension). Turn handle counter-clockwise to unlatch ash door. Ash drawer is located directly behind ash door. Slide drawer out, check capacity, empty if necessary.

DISPOSAL OF ASHES: Ashes should be placed in a metal container with a tight fitting lid. The closed container of ashes should be placed on a noncombustible floor or on the ground, well away from all combustible materials, pending final disposal. If the ashes are disposed of by burial in soil or otherwise locally dispersed, they should be retained in the closed container until all cinders have been thoroughly cooled. Note: Ashes can still be hot after 24 hours under the right conditions.

2. Replace ash drawer, close and latch ash door.
3. Check hopper capacity, fill if necessary. Remove any fuel that may rest on hopper ledge. Close hopper lid.

DIAGNOSTIC FEATURES

The following diagnostic information is being provided in the event the stove is not functioning properly. It will guide you through possible problems and solutions.

Note the 5 LED lights on the control board. (These are used to determine the heat level settings.)

POWER RESET:

When all lights on control board are simultaneously lit and the circuit control board is not responding:

1. Unplug stove.
2. Wait 10 seconds.
3. Plug stove back in and resume as normal.

INTERNAL ALARM:

If the control board becomes unresponsive and the fire goes out, the control board is in 'Internal Alarm'.

The control board has sensed one of the safety sensors. Allow stove to cool approximately 30 minutes. After this time, it will diagnose the problem. The #2 & #3 LED lights are used to diagnose certain causes for stove shutdown.

PROOF OF FIRE SWITCH: If exhaust temperature does not reach 110° F, or during operation, the temperature drops below 90° F, the stove will go into 'Safety Shutdown' mode. When stove completes safety shutdown, the #3 LED light will start blinking.

VACUUM SWITCH: Vacuum inside the firebox must be present for proper operation. If vacuum is not present, the auger will stop and the stove will go into 'Safety Shutdown'. When Safety Shutdown is complete, the #2 LED light will start to blink.

See page 16 for additional information.

SHUTTING THE STOVE 'OFF'

1. Press the ON/OFF button once, the lights will turn off and the fire will go out in a few minutes.
2. Room air fan and exhaust fan will remain 'ON' until stove has cooled slightly. The exhaust fan will continue running for 10 minutes.
3. DO NOT unplug the stove to turn 'OFF'. This may cause a significant amount of smoke to remain in firebox or escape into the room.

MAINTENANCE INSTRUCTIONS

Specific features have been designed into this stove which will simplify required daily, weekly, monthly and annual maintenance procedures. The frequency at which these must be performed depend upon quality of fuel burned and fuel rate.

DAILY MAINTENANCE

1. EMPTY THE BURN POT:

It is not necessary to remove any component from stove or open door to empty burn pot into ash drawer.

CORN USAGE: Empty burn pot after 8-12 hours of usage or as needed depending on heat level setting.

WOOD PELLETS: Empty burn pot after 20-24 hours or as needed depending on heat level setting.

50/50 CORN-PELLET MIXTURE: Empty burn pot after 12-14 hours or as needed depending on heat level setting.

TO EMPTY BURN POT

- A. Pull the burn pot handle toward the front of stove and release.
- B. When burn pot has been emptied, relight stove following procedures on pages #6 & #7 in this manual.

CORN USAGE: If needed, a serrated edged tool has been included with your stove to aid in breaking corn 'clinkers'. To use, open door, break clinker with serrated edge of tool. Empty burn pot into ash drawer. Close & latch door.

TIP: Emptying burn pot more frequently will avoid the formation of an extremely hard clinker.

TIP: If a 50/50 corn / pellet mix is used, clinkers will not form.

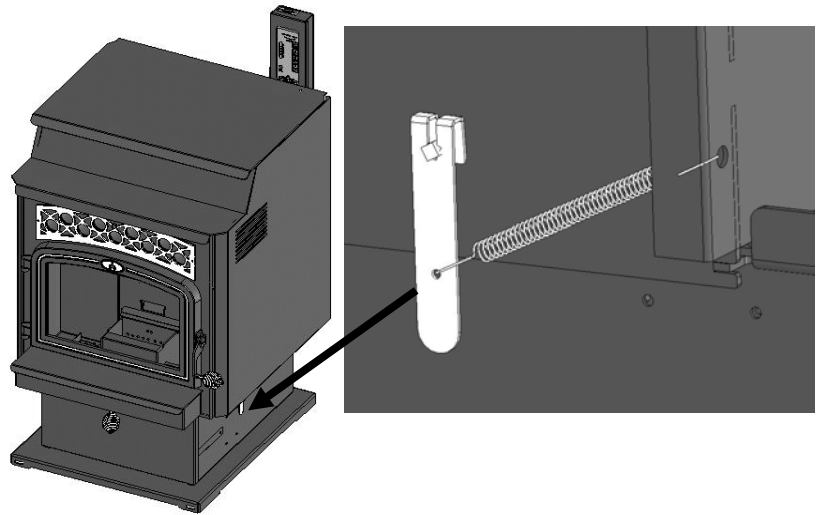

2. HEAT EXCHANGE TUBES

Clean the heat exchange tubes, located above the baffle at the top of the firebox by pulling and pushing the rod in and out several times. Refer to drawing on page 1. Note: Non-serrated end of tool used to break clinkers designed to aid in this task.

3. GLASS CLEANING

Clean glass as needed with a dry, soft cloth to remove residue. Allow glass to cool before cleaning. If residue does not easily wipe off, apply a glass cleaner and burnt ash onto cloth and wipe clean. **DO NOT SPRAY GLASS WHEN HOT!**

WEEKLY MAINTENANCE

In addition to daily maintenance, the following procedures should be performed on a weekly basis during heating season. This will ensure proper performance and maximize efficiency.

CAUTION: Turn the stove 'OFF' and allow time to cool before handling any components.

CLEANING TOOLS NEEDED:

Whisk broom or soft bristled paintbrush, Shop Vac or the like. (An ash vacuum is recommended.)

CAUTION: All debris, ashes, etc. must be completely cooled before using vacuum.

Do not use vacuum to clean hot debris.

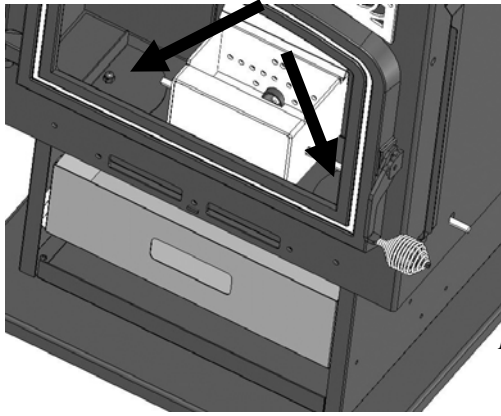

Figure 1

1. Vacuum inner door ledge.
2. Check burn pot for blocked / plugged holes. Clean as necessary.
3. Open secondary floor panels, brush debris through openings into ash drawer. Close panels. Figure 1.
4. Vacuum any remaining debris.

5. CLEAN ASH DRAWER:

- A. Open ash door below hearth extension shelf. Figure 2.
- B. Remove the ash drawer and dispose of ashes. Figure 3.
- C. Vacuum ash drawer opening, ash door and hinge.
- D. Reinstall ash drawer, close and latch door.



Figure 2



Figure 3

2-MONTH MAINTENANCE

If stove is used on a daily basis, the following must be performed at least every other month during the heating season in addition to daily and weekly procedures. More or less frequent maintenance may be required depending on operational use and amount of fuel burned.

CAUTION: Turn the stove ‘OFF’ and allow time to cool before handling any components.

OPTIONAL: Place drop cloth around stove to protect floor covering and surrounding furnishings.

1. REMOVE THE BURN POT

- A. Disconnect ash dump handle spring from stove.
- B. Remove damper handle.
- C. Remove burn pot assembly (with ash dump handle attached) from firebox by lifting up & out of slots in center panel while angling to remove.
- D. Clean burn pot, check for blocked air holes. Set aside for later re-installation. Figure 1.

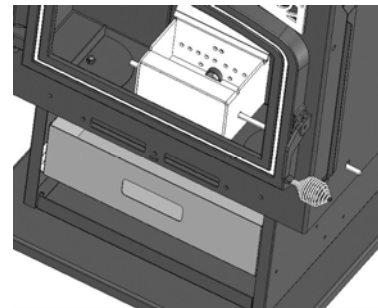

Figure 1

2. REMOVE THE SECONDARY FLOOR PANEL:

- A. Brush debris on secondary floor panel through opening into ash drawer. Figure 2.
- B. Vacuum any remaining debris.
- C. Remove secondary floor panel from firebox.

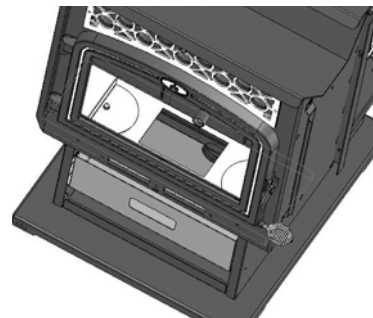
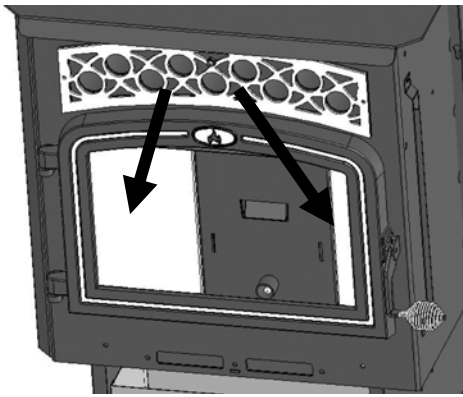

Figure 2



3. REMOVE & CLEAN THE COMBUSTION PASSAGE PANELS & AUGER CHUTE PANEL:

- A. Remove wing nuts securing left & right combustion passageway panels. Remove panels from firebox. Figure 3.
- B. Remove center auger chute panel.
- C. Clean fly ash & debris from panels and firebox interior.

Figure 3

4. CLEAN ASH DRAWER COMPARTMENT:

- A. Locate clean out panel on back wall behind ash drawer. Loosen screws and remove panel. Vacuum area behind panel. Figure 4.
- B. Re-install and secure clean out panel.
- C. Re-install ash drawer, close and latch.

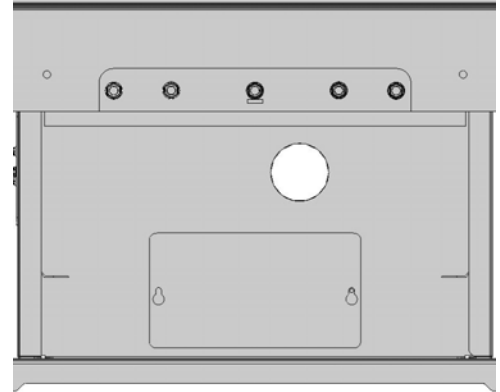

Figure 4

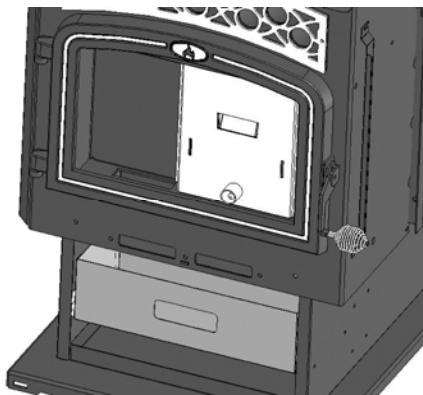

Figure 5

5. Re-install center panel at back of firebox, aligning tube around igniter probe. Figure 5.

IMPORTANT: Igniter must extend to end of tube.

6. Re-install left & right combustion passageway panels. Secure with wing nuts previously removed. Figure 6.

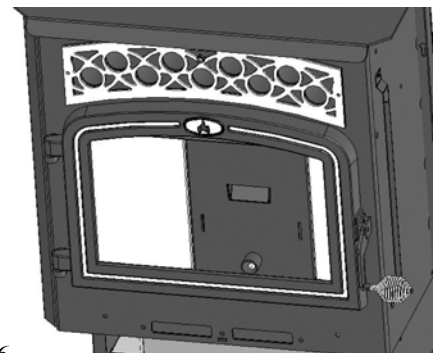

Figure 6

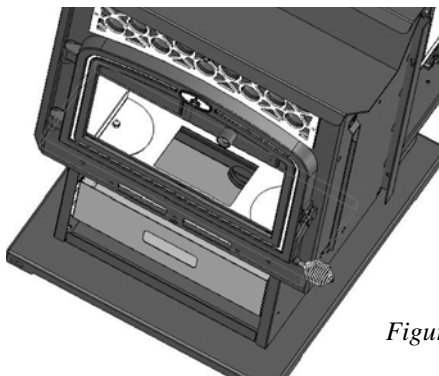

Figure 7

7. Re-install secondary floor panel with narrow edge toward the back, into firebox as shown in Figure 10. Note: When seated correctly, tabs on underside of panel will sit down into square opening in firebox floor. Figure 7.

8. Center ash dump rod. Angle burn pot into firebox. Insert tabs on back side of burn pot into slots in center panel. Push burn pot down onto floor panel. Figure 8.
9. Slide ash dump rod through hole on right side of firebox until it extends 1" beyond firebox. With ash dump in the closed position, place ash dump handle onto rod.

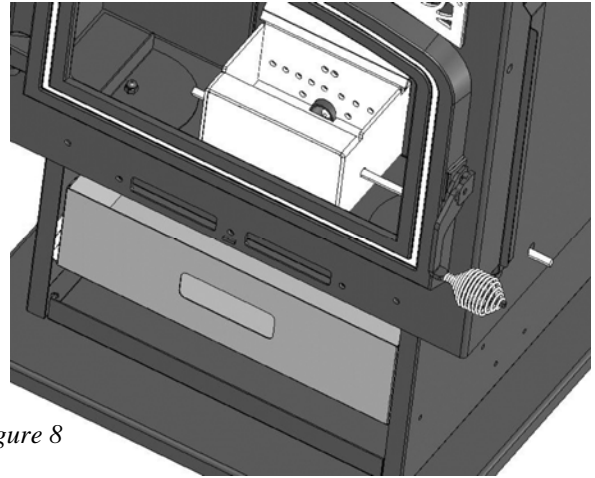
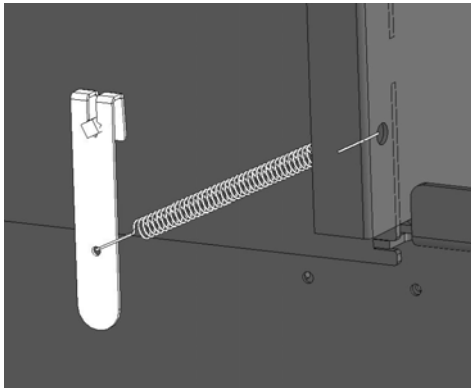

Figure 8



10. Attach one end of spring to hole in "L" flange, placing hook around corner of flange. Attach other end of spring to handle. Figure 10.

Figure 10

11. EXHAUST SYSTEM

It is recommended that the exhaust system is checked for soot accumulation at least every other month during the heating season.

12. GASKETS

Inspect condition of rope gasket around door, glass, ash door and hopper lid. Replace if necessary. Replacement parts are listed at the back of this operating / maintenance manual.

ANNUAL MAINTENANCE

Performing annual maintenance in addition to daily, weekly, and monthly maintenance will prolong the life of the stove, maintain its appearance and ensure safe, reliable operation for the next heating season.

CAUTION: Turn the stove 'OFF' and allow time to cool before handling any components.

Your dealer may offer an annual service / maintenance contract which you may want to take advantage of. There's nothing more comforting than knowing that your stove has been cleaned, inspected and serviced by a factory-trained technician.

1. Completely empty hopper and burn pot at end of heating season.
2. Exhaust system should be thoroughly cleaned and inspected. Contact your dealer to perform this service.
3. Unplug stove from outlet.
4. Locate left side clean out panel (below firebox side panel). Figure 1. Loosen screws and remove panel. Vacuum area behind clean out panel.
5. Carefully clean or vacuum entire area around fan and motor.
CAUTION: Any electrical wires that become disconnected should be serviced by your dealer.
6. Re-install left clean out panel and secure.

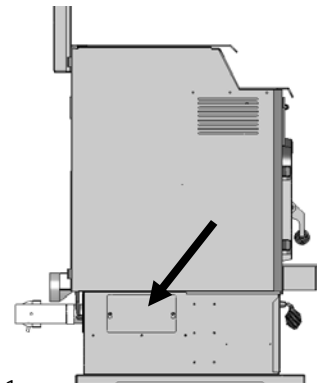

Figure 1

TROUBLESHOOTING

NOTE: The word “fuel” refers to corn, wood pellets, or a mixture of both.

PROBLEM	REASON	SOLUTION
Loss of fire.	Intake air damper open too far.	Close intake air damper to correct setting. See chart on page 7.
	Auger empty at start up.	Press ‘Auger’ button to feed fuel to burn pot.
	High wind directed toward termination cap.	Block wind from termination cap. This may require a different cap. Contact your dealer for more information.
	Insufficient fuel in burn pot at startup.	Use 1 cup or 8 oz. of pellets in the burn at startup.
	Lack of vacuum inside firebox.	Check that all doors and panels are closed / secured.
Auger stops feeding fuel.	Hopper lid open or fuel blocking lid from closing.	Clean ledge between hopper and hopper lid. Close hopper lid.
	P.O.F. switch not detecting heat.	Begin start up procedures again.
	Loss of negative pressure inside firebox.	Check that all doors and panels are closed / secured.
	High wind directed toward termination cap.	Block wind from termination cap. This may require a different cap. Contact your dealer for more information.
Burn pot floods soon after startup. Burn pot floods after burning several hours.	Burn pot not dumped from previous burn, causing air inlet holes to plug, or too much fuel placed in burn pot before lighting.	Empty burn pot before starting new fire. Corn: Empty burn pot every 8-12 hours or as needed depending on heat level setting. 50-50 corn/pellets: Empty burn pot every 12-14 hours or as needed depending on heat level setting. Pellets: Empty burn pot every 20-24 hours or as need depending on heat level setting. (This will depend on operation use and amount of fuel burned).
		Burning corn on “PELLET” setting.
	Moisture content of corn above 15%.	Use corn that is between 12 and 15% moisture content.

CIRCUIT CONTROL BOARD DIAGNOSTIC TROUBLESHOOTING

PROBLEM	REASON	SOLUTION
#2 LED light blinking. (Indicates lack of vacuum in stove).	Door (s) or clean out panel (s) open.	Check that all doors and clean out panels are closed / secured.
	High wind directed toward termination cap.	Block wind from termination cap. This may require a different cap. Contact your dealer for more information.
	Vacuum hose disconnected from either end.	Connect vacuum hose.
	Vacuum hose plugged.	Unplug vacuum hose.
	Vacuum switch wires loose or disconnected.	Connect vacuum switch wires.
# 3 LED light blinking. (Indicates P.O.F. switch is not detecting sufficient heat).	Hopper and fuel pot empty	Reload and restart. Hold auger button until fuel drops into burn pot.
	Burn pot empty / fuel in hopper indicates plugged auger	Empty hopper and look for blockage. Large pieces of cob, small rocks or metal objects are the usual problem. This may cause the auger motor shaft to break. CAUTION: Unplug from outlet before performing this procedure.
	Burn pot flooded. (Filled and ran over edge).	Empty burn pot into ash drawer, remove burn pot and clean all port holes. Empty ash pan and vacuum (or sweep) excess flyash. Follow startup procedures to re-light stove.

REPLACEMENT PARTS

Replacement parts are available through your local dealer. Contact them for availability and pricing.

NO.	PART NUMBER	DESCRIPTION
1	OLV-BRD	CONTROL BOARD
2	OLV-POT	BURN POT ASSEMBLY (5 PC.)
<i>2A</i>	<i>OLV-BPH</i>	<i>BURN POT HOUSING</i>
<i>2B</i>	<i>OLV-ADP</i>	<i>ASH DUMP PANEL</i>
<i>2C</i>	<i>OLV-ADR</i>	<i>1/4" ASH DUMP ROD</i>
<i>2D</i>	<i>OLV-ADH</i>	<i>ASH DUMP HANDLE</i>
<i>2E</i>	<i>500114</i>	<i>HANDLE SPRING</i>
3	OLV-SFP	SECONDARY FLOOR PANEL
4	OLV-606	ASH DRAWER
5	OLV-CPP	COMBUSTION PASSAGEWAY PANELS (2 PER - 1 LEFT, 1 RIGHT)
6	OLV-CAC	CENTER AUGER CHUTE PANEL
--	825	GLASS GASKET
--	826	DOOR GASKET
--	827	ASH DRAWER GASKET
--	828	HOPPER GASKET
--	OLV-204	2" OUTSIDE AIR CONNECTION PIPE (4 FT. LENGTH)
--	150-450	GLASS - 9 1/2" X 14 1/2"
--	300-094	DOOR PINS (2)
7	OLV-LAT	LATCH ASSEMBLY
8	OLV-028	ROOM FAN
9	OLV-038	EXHAUST FAN
10	404-4	PROOF OF FIRE SWITCH (P.O.F.)
11	404-5	HIGH LIMIT SWITCH
12	404-6	VACUUM SWITCH
13	404-7	CORN/PELLET ROCKER SWITCH
14	404-8	SAFETY INTERLOCK SWITCH
15	OLV-AUG	AUGER
--	OLV-BUS	AUGER BUSHINGS
16	OLV-MTR	AUGER MOTOR
17	OLV-032	ELECTRONIC IGNITER
18	OLV-ITD	INTAKE AIR DAMPER
19	OLV-TTT	THERMOSTAT TERMINALS

Illustration on following page.

Consult your dealer for information on options and accessories for this model.

Manufactured by:

Hussong Mfg., Co., Inc.
204 Industrial Park Drive
Lakefield, MN. 56150

Tested & Certified by:

OMNI- Test Laboratories
5465 SW Western Avenue
Beaverton, Oregon 97075
June 2007

