

A breath of fresh air for pellets

BioWIN

Wood pellet boiler

Output range: 2.9 to 25.9 kW

Cascade options up to 78 kW

windhager

HEAT WITH VISION



Wood pellets

A woman with long brown hair and a young girl with blonde hair are smiling and embracing each other in a field of tall grass. The woman is wearing a grey and white patterned sweater, and the girl is wearing a red cardigan over a beige top. The background shows a lush green hillside under a clear sky.

A breath of fresh air

BioWIN

Safe heat with convenience

Within a very short time, heating with pellets has become established as a popular and widely used way of supplying heat. This is no wonder, because pellet heating systems are not only particularly environmentally friendly, they also offer the highest levels of heating comfort with the latest technology. Windhager is once again showing how convenient, efficient and environmentally friendly heating with pellets can be: with the BioWIN.

BioWIN – all the advantages at a glance

UNBEATABLE IN TERMS OF COMFORT

- Innovative automatic cleaning functions, such as heating surface cleaning and ash removal, ensure little maintenance work (BioWIN Exklusiv)
- Large ash box integrated in the unit (BioWIN Exklusiv) ensures long emptying intervals (only 1–3 times per heating season)
- Patented, unique and flexible feed system with up to 8 removal probes ensures that new supplies of pellets are provided automatically

UNPARALLELED IN TERMS OF ECONOMY

- Robust, long-life stainless steel burner ensures low pellet consumption and high efficiency
- Particularly low and compact design – enough room for it even in boiler rooms with a low ceiling
- Satisfies all emissions-related requirements

RELIABLE AND SAFE

- Robust, wear- and maintenance-free ignition element
- Reliable new supplies of pellets provided by patented, pneumatic feed system with three independent removal probes

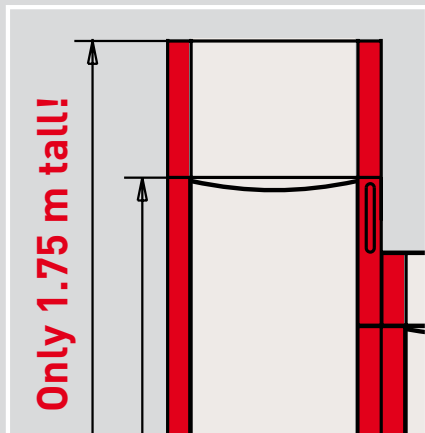

1

1 Compact design

The compact design of the BioWIN means it can be installed in the smallest boiler rooms. If access has to be by narrow and steep steps, the boiler can even be dismantled into several easily transportable sections in order to deliver.

The advantages for you

- Can even be installed in boiler rooms with a low ceiling
- Takes up little space in the installation room, requiring just 0.75 m² floorspace
- Easy and safe to deliver

3

2 Fully automatic, patented feed with 1, 3 or up to 8 removal probes provides a long-term assured pellet supply

3 Fully automated cleaning mechanisms

„Switch on and forget“. Once the BioWIN has been commissioned, the innovative fully automated systems ensure that you don't need to worry about anything else.

The advantages for you

- Fully automated burner bowl ash removal
- Fully automated heating surface cleaning ensures a continuously high degree of efficiency and low fuel consumption (BioWIN Exklusiv)
- Fully automated ash removal for long intervals between maintenance – must only be emptied 1 to 3 times per year (BioWIN Exklusiv)

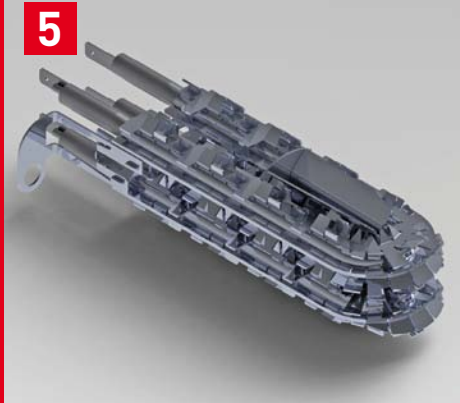
5

4 Large reserve supply container of 150 kg pellets enables long, uninterrupted burning phases

5 Maintenance-free, long-life ignition element

The operational safety of a pellet boiler is significantly dependent on the function and stability of an ignition device. The BioWIN ignition element is a guarantee part, not a wearing part – unique in the market!

The advantages for you

- Guaranteed long service life and functional reliability
- Maintenance-free
- Low maintenance costs

7

6 Precise control of the boiler capacity with the infinitely variable combustion fan

Cogent to the smallest detail

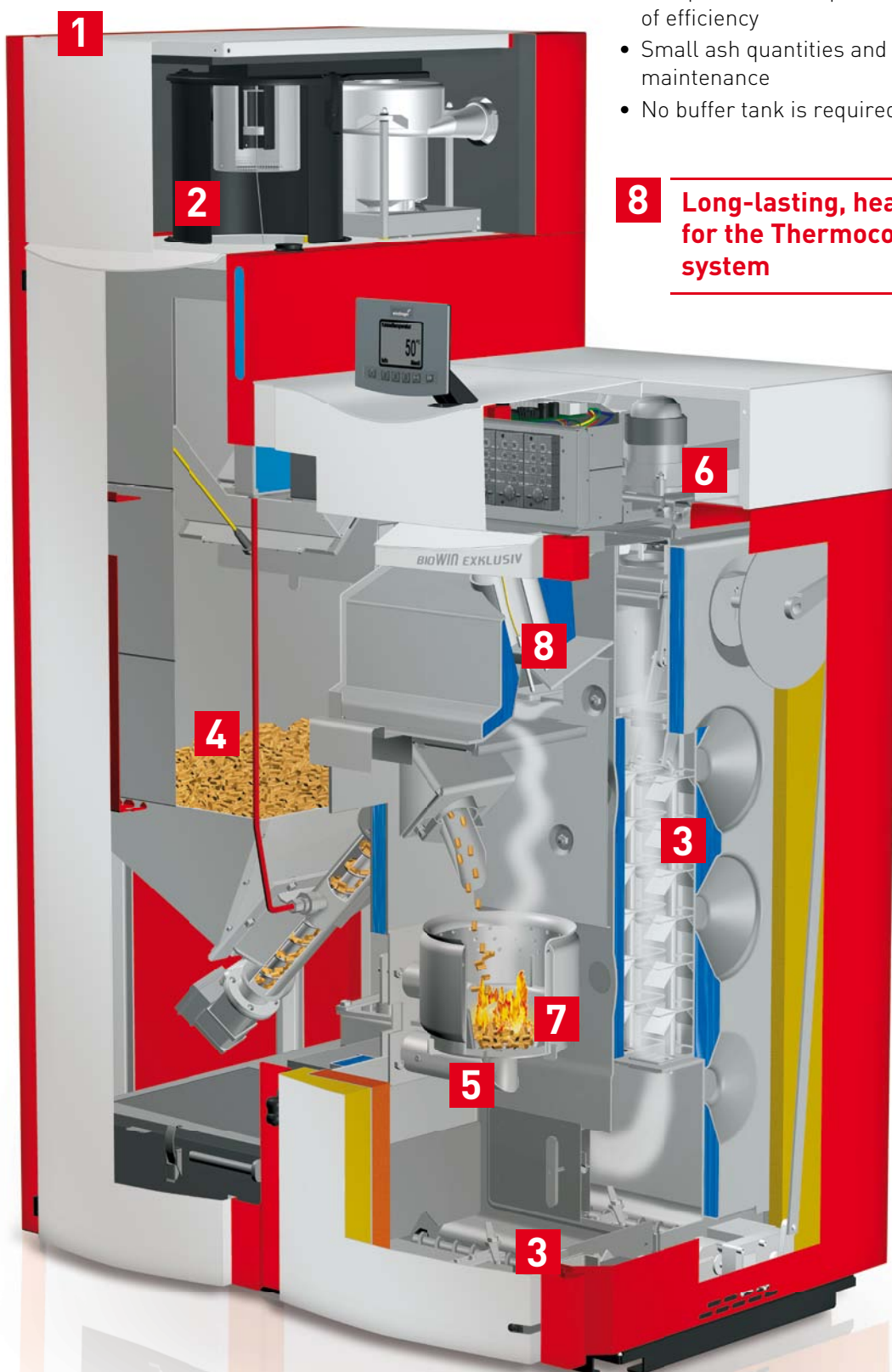

7 Modulating stainless steel burner

The burner technology has proven itself thousands of times over and delivers the best combustion results, even in the lowest performance range.

The advantages for you

- Low pellet consumption and consistently high level of efficiency
- Small ash quantities and long intervals between maintenance
- No buffer tank is required

8 Long-lasting, heavy-duty thermal probe for the Thermocontrol combustion control system

Comfort when you need it

You can choose between three comfort classes – Exklusiv, Premium or Klassik – depending on the level of comfort and convenience you require. Each of these comfort classes is offered in four performance levels (10, 15, 21 and 26 kW) and two control versions (REG and MES^{PLUS}). With 24 boiler solutions, the BioWIN is tailored to meet your individual requirements in all ways.

	Exklusiv	Premium	Klassik
			
Maintenance interval*	1 to 3 times in a year	≤ up to 2 months	≤ up to 7 days
Heating surfaces cleaning	fully automated	manual	manual
Ash removal	fully automated	none	none
Pellet feed	fully automated	fully automated	manual

*The actual maintenance interval depends on the operating method and the pellets used. Please refer to the operating instructions for details

Everything under control

MES^{PLUS} Modular Energy System

The measure of all things: MES^{PLUS} takes on the entire heat management of the heating system. It controls and optimises heat production and distribution matched precisely to requirements. Its modular design ensures that the heating system can be expanded at any time.

REG standard control unit

The REG standard control units offer a high level of control and operating convenience for one heating and one hot water tank circuit. The heating circuit cannot later be extended, and no further combinations are possible.



MES^{PLUS}
User Controller



MES^{PLUS}
Temperature
Controller



Digital REG
user module

Versatile and flexible

Looking to combine the BioWIN with a solar-heating system? Planning an expansion to your heating system? No problem. The BioWIN can handle the operation of single or multiple-circuit systems, underfloor heating and/or radiators. As with all heating solutions from Windhager, the BioWIN is optimally equipped for use with other systems. So you save both time and money when installing the system.

When it comes to heating, you'll find everything under one roof at Windhager. Windhager provides solutions and components for all fuels and every need. You not only have a single source for all your needs, you have the security that everything will work together perfectly – and that with the unique function guarantee on Windhager systems.



BioWIN
Pellet central heating boiler

EasyWIN
Wood gasification boiler

MES^{PLUS}
user module(s)

SolarWIN
Pellet and solar – the
perfect combination for
carbon neutral heating

System distributor

AccuWIN Solar
Accumulator tank with
Fresh Water Station

The optimal pellet storage room

The fully automated pellet feed

To replenish the pellets, Windhager offers a fully automated feed system patented throughout Europe that carefully transports the pellets in an air current.

General advantages of the pellet feed system

- Unequalled flexibility, since the position of the storage room can be independent of the boiler room
- Totally maintenance-free system
- Easy and fast planning as well as installation
- No moving parts and no electrical cables necessary in the storage room
- Careful pellet transport – without stirring up dust – to the boiler

This pneumatic pellet supply system can be easily and flexibly adapted to the local conditions and requirements. In addition, there are 3 removal variants to choose from:

8 probes with automatic changeover unit

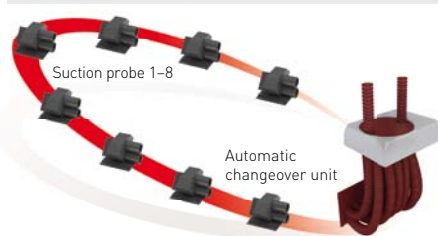

Additional advantages of 8 probes

- Maximum safety during pellet transport due to several separate removal points
- 8 probes can usually take the place of an inclined floor and therefore greatly increase the storage volume
- Automatic function check – "Rinsing" and "Changing over"
- If necessary, the pellet store can be split into 2 zones

Storage dimensioning:

Building heat load in kW x factor 0.75 = storage room volume in m³

3 probes with automatic changeover unit

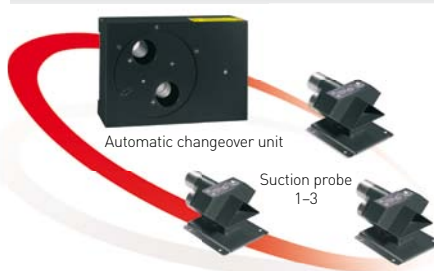

Additional advantages of 3 probes

- Maximum safety during pellet transport due to several separate removal points
- Automatic function check – "Rinsing" and "Changing over"

Storage dimensioning:

Building heat load in kW x factor 0.9 = storage room volume in m³

1 probe with "agitation" for sheet steel and fabric tanks



Additional advantages of 1 probe with "agitation"

- High operational safety due to integrated "agitation" mixer
- Low purchase price
- Ideal solution for small pellet quantities

Storage dimensioning:

sheet steel tanks up to 3.9 to
Fabric tanks up to 9 to



8 probes with automatic changeover unit

To replenish the pellets, Windhager offers a fully automated feed system patented throughout Europe that carefully transports the pellets in an air current.

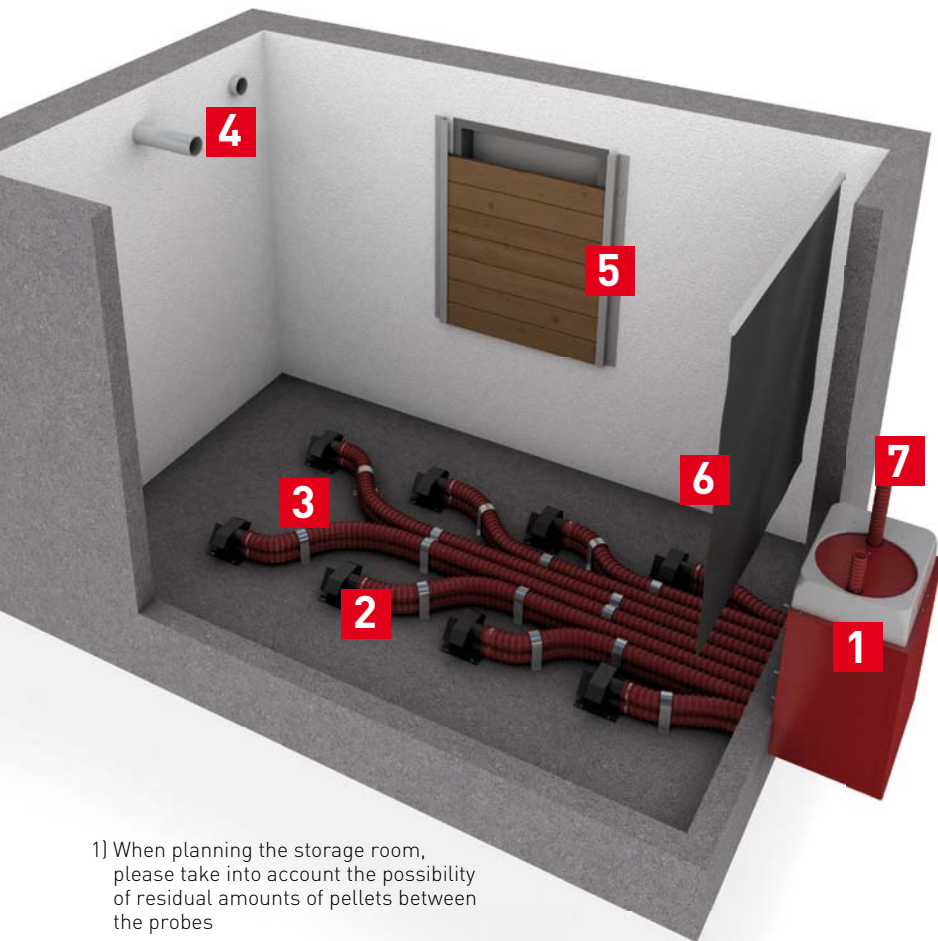

- 1** Changeover unit (BIO008) with fire-protection cladding (BIO009)
- 2** Removal probe: Up to eight removal probes and divisible into two zones
- 3** Fastening clips for delivery hose (BIO011 – pack of 6)
- 4** Filling and return air pipes for filling the storage room via pellet tanker
- 5** Z-angle (PMX016) for storage room door panels with 30 mm thickness
- 6** Impact mat (PMX017) made of plastic
- 7** Flexible delivery and return air hose for transporting pellets to the BioWIN XL pellet boiler

1) When planning the storage room, please take into account the possibility of residual amounts of pellets between the probes

This unique development is excellently suited to a wide range of storage room conditions

Pellet storage room

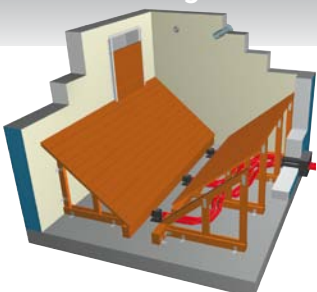

Sheet steel tank



Fabric tank



Earth tank



The optimal pellet storage room

The correct dimensioning

The storage room should be large enough to store the quantity of fuel required for one year. The size of the storage room depends on the building heating load. In principle the following rule of thumb applies:
 Building heating load in kW x factor 0,9 m³/kW
 = storage room volume in m³ (incl. empty space)

Example 1

Single-family house with building heating load of 15 kW:
 15 kW x 0,9 m³/kW
 = 13,5 m³ storage room volume
 that corresponds to a room of approx. 2 x 3 m floor area and 2,25 m height.

Example 2

Duplex house with building heating load of 26 kW:
 26 kW x 0,9 m³/kW
 = 23,4 m³ storage room volume
 that corresponds to a room of approx. 2,6 x 4 m floor area and 2,25 m height.

Section through the storage room – Front view

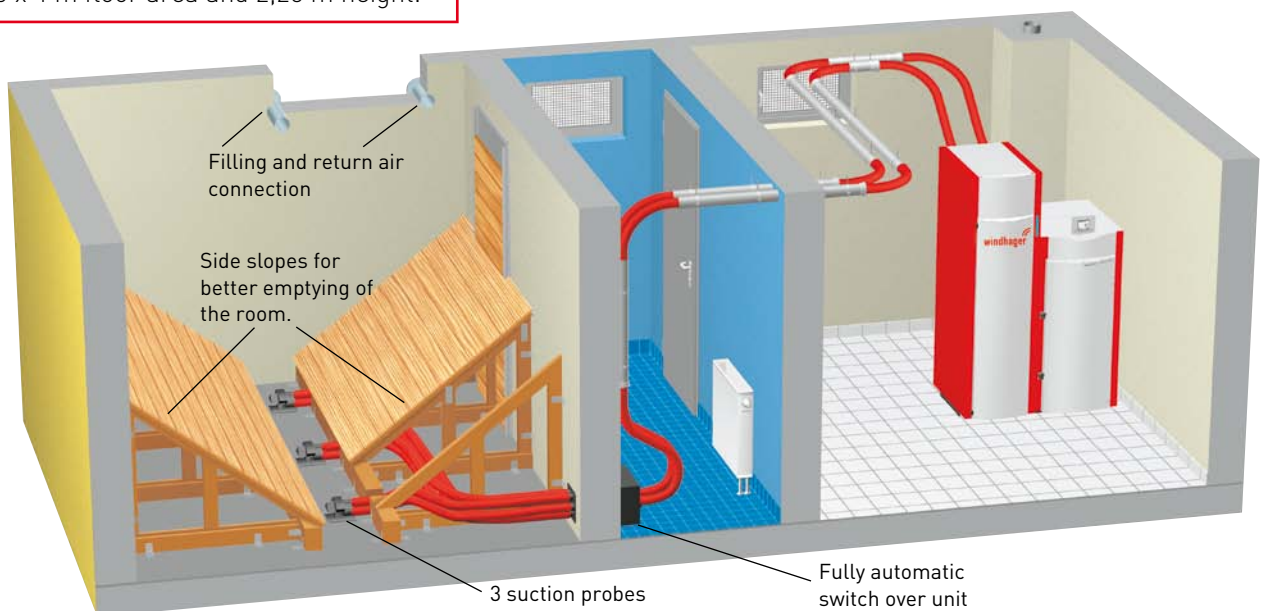
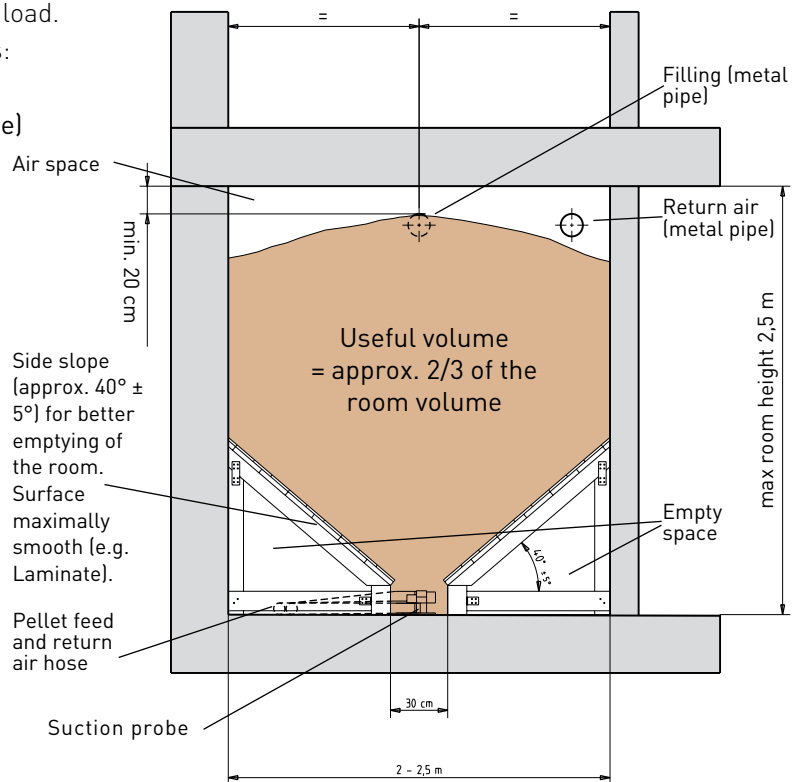

Warmth when you need it

BioWIN

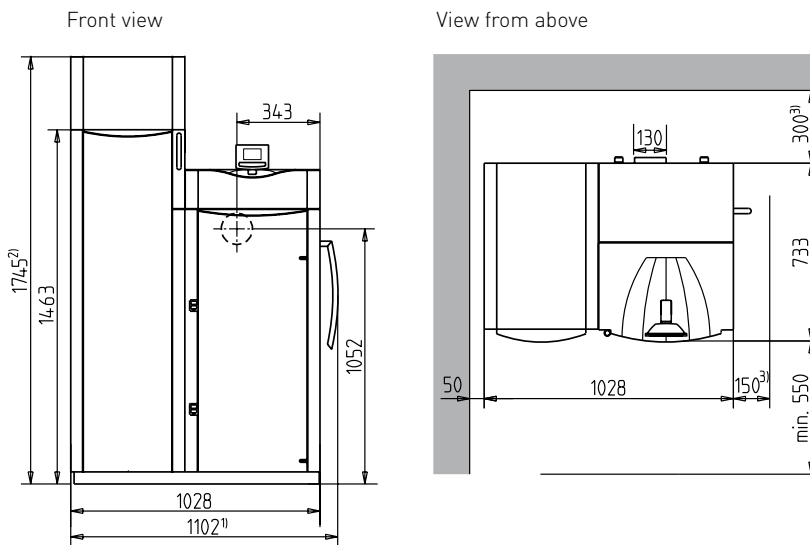

- 1) Only for Klassik/Premium types
- 2) Only for Premium/Exklusiv types
- 3) The minimum distance can be reduced by up to 50 mm on request

All measurements in mm

Technical data BioWIN

Type		BioWIN 100	BioWIN 150	BioWIN 210	BioWIN 260
Rated output range	kW	2.9 – 9.9	4.4 – 15.0	6.1 – 21.0	7.5 – 25.9
Pellet reserve supply container capacity	kg	150.8	150.8	150.8	150.8
Installation dimensions W x D x H (in the wood partition)	mm	1.200 x 790 x 1.610			
Flue gas connection diameter	mm	130	130	130	130
Power consumption at nominal load	W	46	58	100	110
Power consumption Part load	W	27	32	40	47

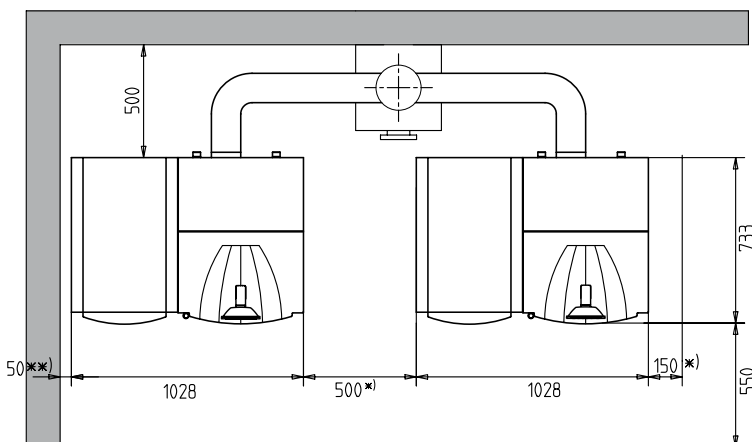

BioWIN Cascade (BWE390/520)

View from above

- * Each individual BioWIN requires an access space of 500 mm (to either the left or the right)
If this access is provided, the additional clearance can be reduced to 150 mm
- ** If an access space of 500 mm is provided, this clearance can be reduced to 50 mm

All measurements in mm

Technical data BioWIN Cascade

Model variants		BioWIN 390	BioWIN 520	BioWIN 780
Nominal thermal output range	kW	6.1 – 42.0	7.5 – 51.8	7.5 – 77.7
Comprising		2 BioWIN Exklusiv 210	2 BioWIN Exklusiv 260	3 BioWIN Exklusiv 260

IMPORTANT: Observe details of planning document!

Austria

Windhager Zentralheizung GmbH
Anton-Windhager-Straße 20
A-5201 Seekirchen bei Salzburg
T. +43 (0) 62 12/23 41-0
F. +43 (0) 62 12/42 28
info@at.windhager.com

Windhager Zentralheizung GmbH
Carlberggasse 39
A-1230 Wien

Windhager Zentralheizung GmbH
Tiroler Straße 25
A-6424 Silz

Germany

Windhager Zentralheizung GmbH
Deutzing 2
D-86405 Meitingen bei Augsburg
T. +49 (0) 82 71/80 56-0
F. +49 (0) 82 71/80 56-30
E-Mail: info@de.windhager.com

Windhager Zentralheizung GmbH
Heinrich-Rudolf-Hertz-Straße 2
D-04509 Delitzsch bei Leipzig

Windhager Zentralheizung GmbH
Gewerbepark 18
D-49143 Bissendorf

Switzerland

Windhager Zentralheizung Schweiz AG
Industriestrasse 13
CH-6203 Sempach-Station bei Luzern
T. +41 (0) 41/469 469-0
F. +41 (0) 41/469 469-9
info@ch.windhager.com

Windhager Zentralheizung Schweiz AG
Rue des Champs Lovats 23
CH-1400 Yverdon-les-Bains

Windhager Zentralheizung Schweiz AG
Dorfplatz 2
CH-3114 Wichtrach

France

Windhager Chauffage Central
France S.A.S.
1, rue du Maire Georges Baruch
Z.A.C. Nord du Rosenmeer
F-67560 Rosheim
T. +33 (0)3 88 81 82 17
F. +33 (0)3 88 95 81 85
info@fr.windhager.com

Italy

Windhager Italia S.R.L.
Via Ungheresca sud
I-31010 Mareno di Piave (TV)
T. +39/04 38/49 91 43
F. +39/04 38/49 78 84
info@windhager.it

United Kingdom

Windhager UK
4, Glenmore Business Park, Vincients Road
Bumpers Farm Industrial Estate, Chippenham
Wiltshire SN14 6BB
T. +44/12 49/44 66 16
F. +44/12 49/65 35 74
info@windhager.co.uk

Your expert PARTNER